

ZE-115-M

Absolute-Incremental-Serial

Operating Manual

Rotary Encoder Art.-No.: 173-00002

Please keep for further use !

Edition-/Rev.-Date: 06.03.01
Document-/Rev.-No.: TR - ECE - BA - GB - 0023 - 01
Soft edition:
File name: TR-ECE-BA-GB-0023.DOC
Author: MÜJ

TR - Electronic GmbH
Eglshalde 6
D-78647 Trossingen

Telephone ++49 (0)7425 / 228-0
Telefax ++49 (0)7425 / 228-33

Corresponding Document:

**Title: Encoder programming
with EPROG**

Art.-No.: TR - E - BA - GB - 0011

Imprint

TR-Electronic GmbH

D-78647 Trossingen
Eglisshalde 6
Tel.: (0049) 07425/228-0
Fax: (0049) 07425/228-33

© Copyright 1999 TR-Electronic

Guarantee

In our ongoing efforts to improve our products, TR-Electronic reserve the right to alter the information contained in this document without prior notice.

Printing

This manual was edited using text formatting software on a DOS personal computer. The text was printed in *Arial*.

Fonts

Italics and **bold** type are used for the title of a document or to emphasize text passages.

Passages written in *Courier* show text which is visible on the screen / display as well as software menu selections.

"< >" refers to keys on your computer keyboard (e.g. <RETURN>).

Copyright Information ©

MS-DOS, MS-Windows and MS-Windows-95 are registered trademarks of Microsoft Corporation.

Revision History

i

Note:

The cover of this document shows the current revision status and the corresponding date. Since each individual page has its own revision status and date in the footer, there may be different revision statuses within the document.

Drawings that are in the appendix have their own revision history.

Document created:

01.10.1999

Revision	Date
Drawing 04-503-002 is replaced by 04-K173-V0001	06.03.2001

Table of contents

1 Safety 5

 1.1 General Potential for Danger 5

 1.2 Safety Information 5

 1.2.1 Installation information..... 6

 1.2.1.1 Screening 7

 1.2.1.2 General Measures for Interference Suppression 7

 1.2.1.3 Wiring the Casing Cover 8

 1.2.1.4 Connecting the Cable Screening to the Casing Cover..... 9

 1.3 Appropriate Use 10

 1.4 Danger Due to Accessories 11

 1.5 Authorized Operators 12

 1.6 Safety Measures at the Place of Assembly 12

2 Transportation / Commissioning 13

 2.1 Transportation / Storage 13

 2.2 Assembly 14

 2.3 Commissioning 15

 2.3.1 Encoder Interface ISI (Absolute-Incremental-Serial) 15

3 Disturbances 17

 3.1 Causes of Faults and Remedies..... 17

4 Appendix 18

 4.1 Technical Data..... 18

 4.1.1 Electrical Characteristic Data 18

 4.1.2 Mechanical Characteristic Data..... 19

 Drawings

 Pin assignment..... TR-ECE-TI-GB-0047

 Dimension drawing 04-K173-V0001

1 Safety

1.1 General Potential for Danger

The ZE-115 rotary encoder cannot function as a stand-alone unit, i.e. it is a component part that is intended to be installed in a complete system consisting of several such components working together. This means that the rotary encoder does not have a direct protection device of its own.

The encoder provides no diagnostics for errors that may occur, such as speed too high, track errors, transfer errors, etc. This means that you must check the received data yourself for validity.

All the persons who are involved in the assembly, commissioning and operation of the device

- must be appropriately qualified
- must follow exactly the instructions in this manual.

This is for your own safety and the safety of your equipment!

1.2 Safety Information

This operating manual contains information that you must comply with to ensure your personal safety and to avoid damage to property. The information is emphasized by warning triangles, which have different appearances to match the level of danger:



Warning

Means that if the appropriate safety measures are ignored, death, severe injury or considerable damage to property can occur.



Caution

Means that if the appropriate safety measures are ignored, slight injury or damage to property can occur.



Note

Emphasizes important information about the product, its properties or helpful hints for using it.

1.2.1 Installation information

Due to the fact that the rotary encoder is normally used as a component part of a larger system, this information is intended to provide a guideline for safe installation of the rotary encoder in its environment.



Warning

- Observe the safety and accident prevention regulations that apply to the specific application.
- In the case of equipment with a fixed connection (stationary installations/systems) without all-pole mains switches and/or fuses, you must install a mains switch or a fuse in the system and connect the equipment to a protective earth.
- Before commissioning devices that are run with mains voltage, check whether the set rated voltage range matches the local mains voltage.
- With a 24-V supply, ensure safe electrical isolation of the extra-low voltage. Use only mains units that comply with IEC 364-4-41 or HD 384.04.41 (VDE 0100 Part 410) standards.
- Fluctuations in or deviations from the rated mains voltage may not exceed the tolerances stated in the technical data. If they do, functional failures of the electrical components and hazardous conditions cannot be ruled out.
- You must take precautions to ensure that, following voltage dips and failures, it is possible to restart an interrupted program in an orderly manner. In this context, no dangerous operating status conditions may occur even for a brief period of time. If necessary, you must force an **EMERGENCY STOP**.
- EMERGENCY STOP devices that comply with EN 60204/IEC 204 (VDE 0113) must remain effective in all the operating modes of the automation equipment. Unlocking the EMERGENCY STOP devices must not result in an uncontrolled or undefined restart.
- Install the connecting and signal lines such that inductive and capacitive interference does not adversely affect the automation functions.
- Install automation technology equipment and its operator input elements such that they are sufficiently protected against being operated by mistake.
- Take appropriate hardware and software measures in the I/O link to prevent possible cable or wire breakages on the signal side leading to undefined status conditions in the automation equipment.

1.2.1.1 Screening

The use of electronic sensor active systems in modern machines makes it crucial to enforce a consistent and correctly executed interference suppression and wiring concept.

These conditions are the only guarantee that systems containing electronic measuring systems will function properly.

Recommended Screened Cable Wiring

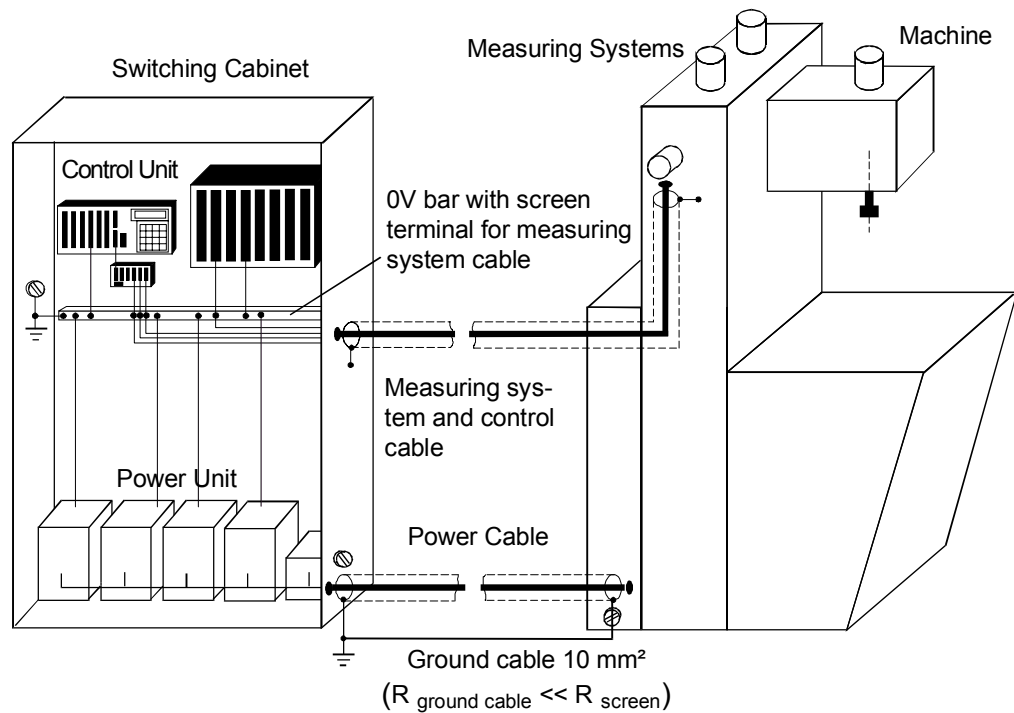

1.2.1.2 General Measures for Interference Suppression

- Route (screened) lines connecting to the encoder either a long way from or completely physically separated from energy lines that carry disturbances.
- Use only completely screened lines for data transfer and ensure they are well earthed. In the case of differential data transfer, (RS422, RS485 etc.), you must additionally use twisted-pair lines.
- Use cables with a minimum cross-section of 0.22 mm² for data transfer.
- Use a ground cable with a minimum cross-section of 10 mm² to avoid equipotential bonding via the screen. In this context, you should ensure that the ground cable's resistance must be much lower than the screen's resistance.
- Wire the screen continuously keeping a large area in contact with special screen connecting terminals.
- Avoid crossing cables. If this is not possible, the cables should only cross at right-angles.

1.2.1.3 Wiring the Casing Cover

i **Note**

The casing cover contains not only the connection terminals but also electronic for generation of the ISI signals. To protect the electronics from environmental influences, we chose a housing that complies with type of protection IP 67 according to DIN 40 050.

Please be sure that during cabling you use the proper cable screw glands and their seals (o-rings). The lid of the housing must be tightened correctly (see "**Appropriate Use**" on page 10). Screw glands and lid must be sealed properly. If dirt or oil will penetrate inside the converter housing the electronic will be damaged.

Connection

You should use the Siemens-specified twisted-pair cables for the positive and negative signals of the ISI data and RS485 signals.

1.2.1.4 Connecting the Cable Screening to the Casing Cover

To prevent disturbance signals entering the encoder housing, we used cable screw glands with which it is possible to connect the screen on the inside. For this reason, **no** connection point for the screen is provided inside the Casing Cover.

Procedure:

1. Screw the cable screw gland into the housing.
2. Dismount the compression nut (1) and the terminal holder (2).
3. Push the compression nut (1) and the terminal holder (2) over the cable.
4. Strip the cable; push back the braiding around the terminal holder (2) such that the braiding goes over the inner O-ring (3) and does not lie over the cylindrical section or the torsional bars.
5. Insert the terminal holder (2) into the intermediate gland (4) such that the torsional bars fit into the intended lengthwise grooves in the intermediate gland (4).
6. Screw the compression nut (1) to the intermediate gland (4).

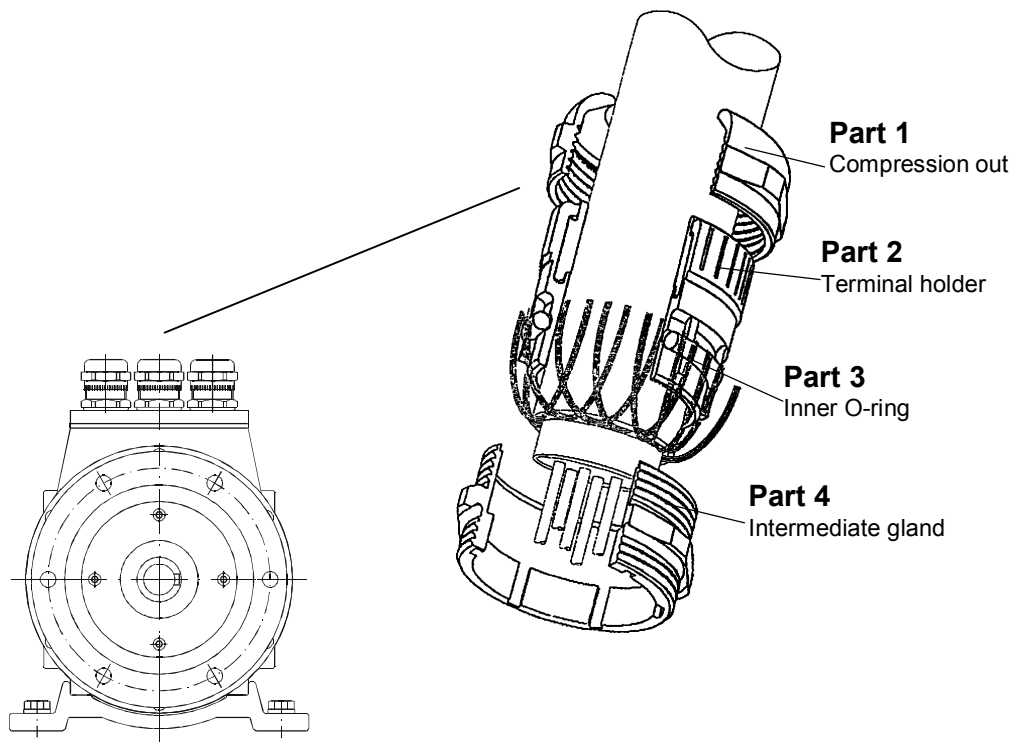

Repeat orders

	Article	Article number
Filler plug:	PG11 (with O-ring)	49-010-006
Cable screw gland:	PG11 (with O-ring)	49-010-003
O-ring:	Field – Bus - Cap	26-000-001

1.3 Appropriate Use

The rotary encoder is used for registering angular movement and for pre-processing measuring data for a downstream controller with an Absolute-Incremental-Serial (ISI) interface.

In order to program the device parameters, you will need the PC program "EPROG", which runs on all commercially available personal computers (PCs) or a Siemens PG 7xx programming unit with an MS-DOS the operating system.

The "EPROG" program is used to set all the device-specific parameters.

In order to programme the device with "EPROG" via the serial RS232 interface, you will need a PC adapter V3.3 or higher from TR-Electronic to perform the conversion from RS 232 to RS 485.



Note

In order to avoid harm at the casing cover and to guarantee the density of the encoder the three screws must be tightened uniformly. Onto a close O-ring seat, it is to be respected.



Warning

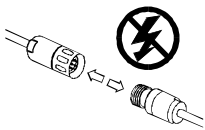

Deenergize the system before carrying out wiring or opening and closing electrical connections!

Short-circuits, voltage peaks etc. can lead to malfunctions and uncontrolled conditions in the system or to serious personal injury or damage to property.

Before switching on the system, check all the electrical connections!

Connections that are made incorrectly can lead to system malfunctions; wrong connections may result in serious personal injury or damage to property.

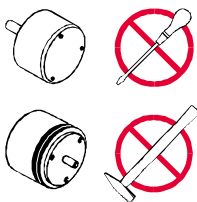

For safety reasons, mechanical or electrical changes to the measuring systems are prohibited!



Caution

- **Avoid radial and axial deviations between the encoder and the drive shaft!**
At assembly, you should use couplings that can take up these forces.
- **Always keep to the operating temperature range of -20° to +70° C!**
- **Keep to the sealing of the Casing Cover (see note on page 10), principal when industrial liquids to run over the housing!**



Note

Always keep to the commissioning, operating and programming instructions specified in this manual.

1.4 Danger Due to Accessories



Caution

Clamps that are not connected correctly in the casing cover can lead to an encoder malfunction!

- Tightly screw the mating connector to its intended connector.

1.5 Authorized Operators

This/a device may only be commissioned by qualified personnel. In the context of the safety-specific information in this document, qualified personnel are considered to be persons who are authorized to commission, ground and mark circuits, equipment and systems in accordance with recognized safety standards.

1.6 Safety Measures at the Place of Assembly



Warning

Do not carry out welding if the encoder has already been wired-up or is switched-on!

Potential fluctuations can destroy the encoder or adversely affect its function.

Do not touch connector contacts with your hands!

Static charges could destroy the electronic components in the encoder.

Keep to the supply voltage range: 11-27 V DC ($\pm 5\%$ residual ripple)



Note

Ensure that the area around the place of assembly is protected from aggressive media (acid, etc.).

2 Transportation / Commissioning

2.1 Transportation / Storage

Transportation Information

Do not drop encoders or subject them to excessive jolting!

The device contains an optical system with glass elements.

Use only the original packaging material!

Incorrect packaging material can cause damage to the device in transit.

Storage

Storage temperature: -30 to +80° C

Store in a dry place.

2.2 Assembly

Drive of the Encoder Shaft

The ZE-115 encoder is connected to the drive shaft by an elastic coupling which takes up deviations in the axial and radial directions between the encoder and the drive shaft. This prevents excessive bearing loading. You can order couplings on request.

Flange Fastening

The 85-mm-diameter centring collar with fit j6 centres the encoder to the shaft. The collar is fastened to the machine by means of six screws in the flange (Figure 1).

Assembly Base Fastening

Since this type of fastening does not allow direct centring of the shaft, you must be particularly careful to line up the encoder shaft with the drive shaft. Fastening to the machine is by means of four screws on the assembly base. Do not mount the link element if exists mechanical tensions.

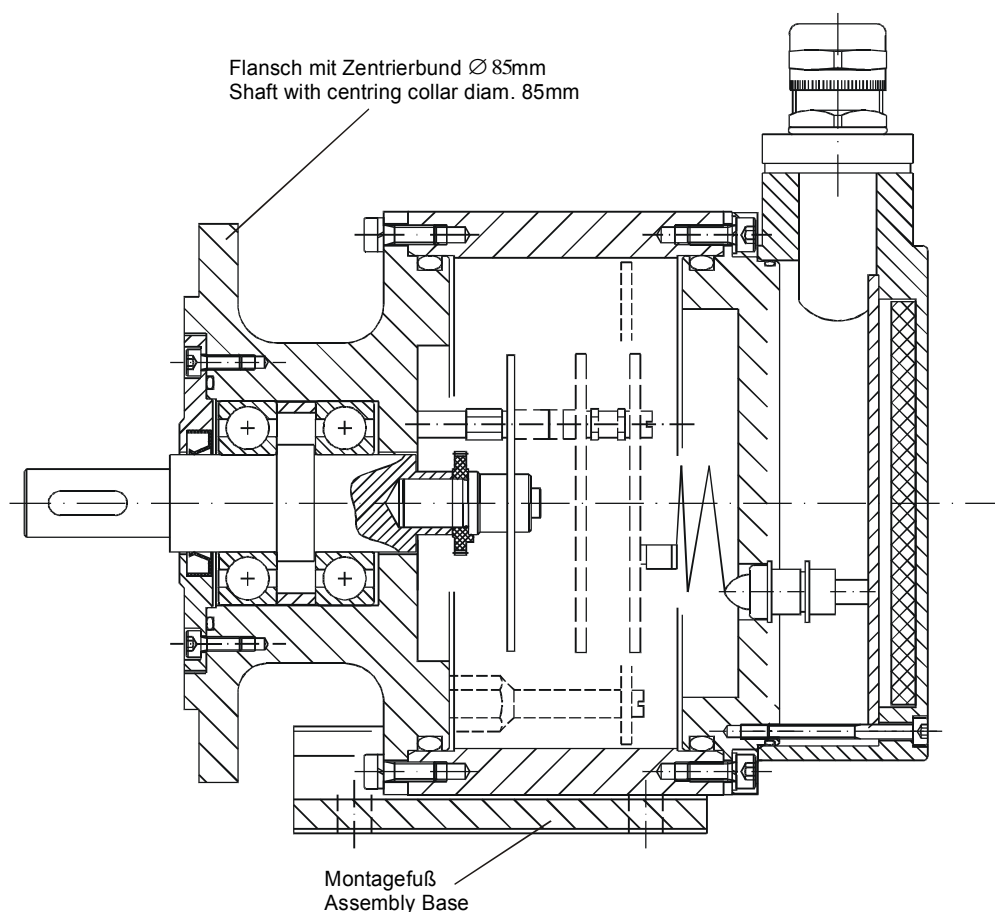

2.3 Commissioning

2.3.1 Encoder Interface ISI (Absolute-Incremental-Serial)

Block diagram

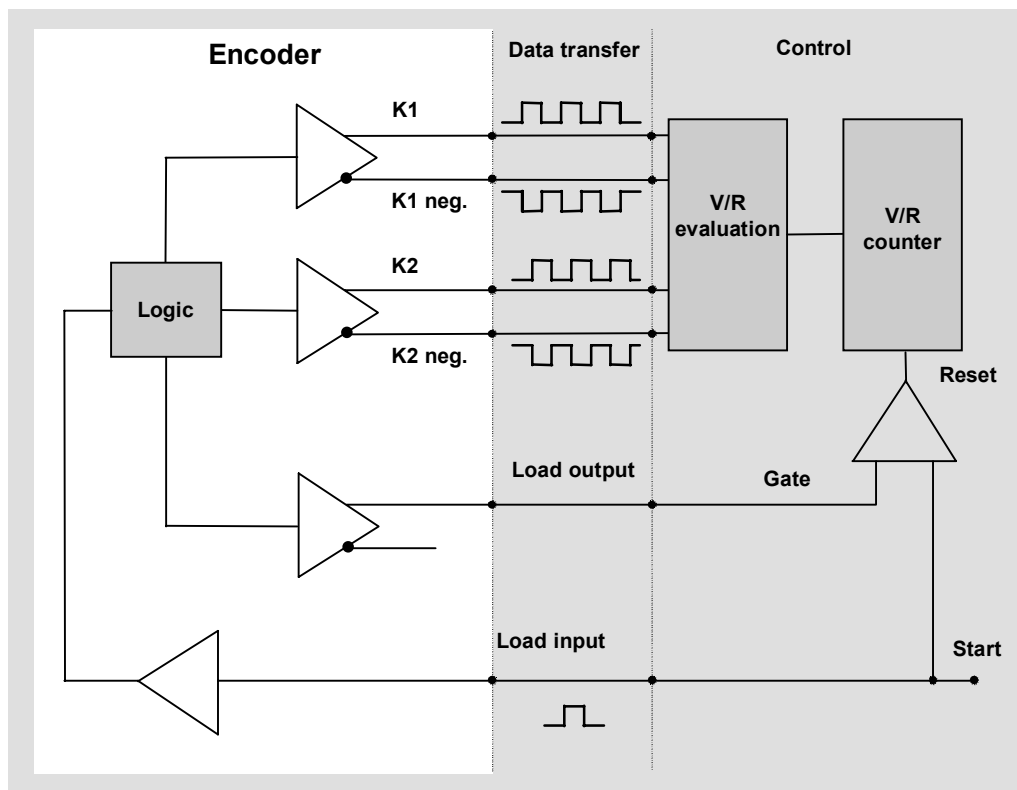

Description

Incremental serial interface for absolute encoders. Changes in position are transferred by two common incremental tracks. The sign of the 90° phase displacement indicates the direction of travel. However, it is not necessary to approach reference points.

Instead, the encoder's loading input is connected to the loading level. The encoder then no longer issues pulses, but switches on its loading output. The incremental counter can now be set to zero and the loading level disconnected from the loading input. The encoder then issues counter pulses until the incremental counter is counted up to the encoder position. When this position is reached, it disconnects its loading output again and is then ready for further loading operations.

Since during the loading operation the incremental counter does not contain a valid position, the axis should not be positioned during that period. To suppress glitches stored in the incremental counter, you should repeat the loading operation at regular intervals, for example when the respective axis is idle.

Channel diagram

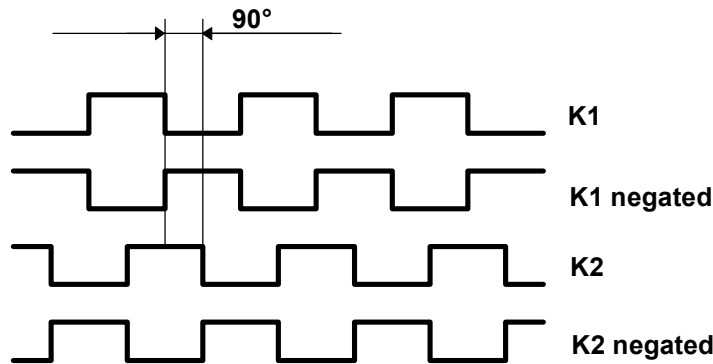

To ensure the same resolution for incremental counter and encoder, all 4 tracks are to be evaluated (on step per edge).

Impulse diagram: loading for loading edge

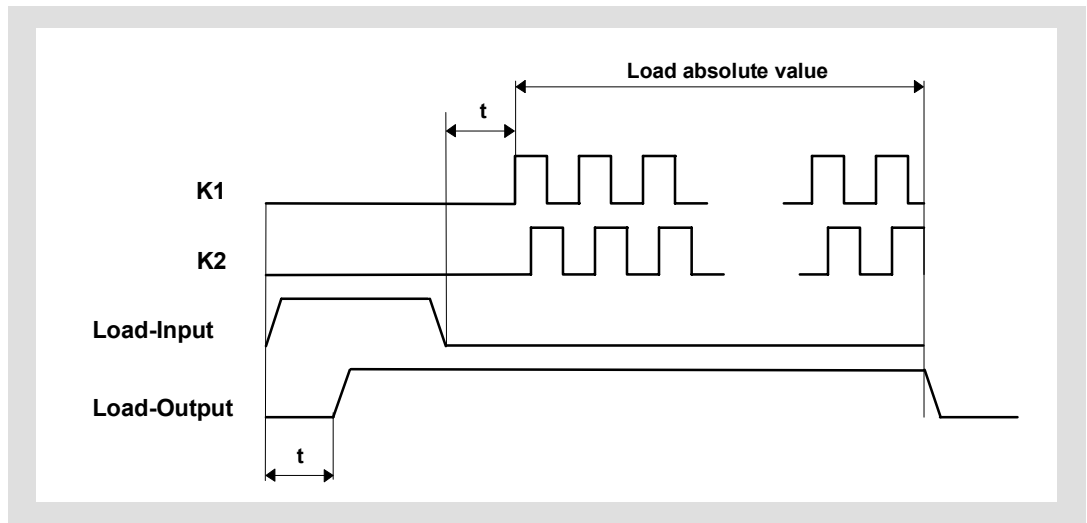

t = delay time, programmable via PC program "EPROG"

3 Disturbances

3.1 Causes of Faults and Remedies

Fault	Cause	Remedy
Encoder step changes	Loose contacts in the wiring	Check all the cabling and wiring used for connecting the encoder.
	Strong vibrations	Vibrations, shocks and jolts, e.g. on presses, are cushioned by so-called "shock modules". If the error persists despite these precautions, the encoder must be replaced.
	Electrical faults EMC	Electrical faults can be countered by means of insulating plastic flanges and couplings, and by data and power supply cables with twisted-pair conductors.
	Excessive axial and radial loading of shaft or scanning defect.	Couplings prevent mechanical strain on the shaft. If the error persists despite this precaution, the encoder must be replaced.

4 Appendix

4.1 Technical Data

4.1.1 Electrical Characteristic Data

Operating voltage:	11-27 V DC (\pm 5% residual ripple)
Max. current consumption:	< 350 mA at 11 V DC, < 150 mA at 27 V DC
Output capacity:	24 bit
Resolution:	4096 steps/rev (12 bit)
Measuring range:	4096 revolutions (12 bit)
ISI data interface:	
Structure:.....	Data: 2-wire acc. to EIA RS422
Screen:.....	Refer to chapter entitled "Installation information" on page 6 to 9
Transmission rate:	2 kHz – 115 kHz
Transmission procedure:.....	absolute-incremental-serial
Inputs:	
Preset1 + 2:	Electronic adjustment
Switching level:.....	1-level > +8V, 0-level > +2V, up to \pm 35V, 5k Ω
Operating temperature range:	-20 to +70°C
Type of protection (double housing):	IP 67 (DIN 40 050)

4.1.2 Mechanical Characteristic Data

Mechanically permissible speed:	3600 RPM
Permissible shaft loading:	100 N axial, 150 N radial (at end of shaft)
Minimum bearing lifetime:	2,8 x 10 ¹⁰ revolutions at:
Operating speed:	3000 RPM
Shaft loading:.....	60 N axial, 90 N radial (at end of shaft)
Operating temperature:.....	60°C
Max. angular acceleration:	≤ 10 ⁴ rad/s ²
Vibration	According to DIN IEC 68-2, Part 6
Form of vibration	sine
Frequency range.....	50 Hz to 2000 Hz
Acceleration.....	≤ 245 m/s ² (25g) peak
Axes	X-, Y- and Z-axis
Duration.....	2 h/axis