

HFV7

AUTOMOTIVE RELAY



Typical Applications

Fog lamp & headlight control, Rear window defogger, Air-conditioning, Power distribution, Fuel pump control, ABS, Traction control system, Cooling fan control, Heating control, Power supply management system, Battery disconnection device

Features

- 70A switching capability
- Extended temp. range up to 125°C
- With transient suppression resistor available
- 1 Form A contact arrangement
- Wash tight and dust protected types available
- RoHS & ELV compliant

CHARACTERISTICS

| | | | |
|---------------------------------------|--|--|--|
| Contact arrangement | 1A | Ambient temperature | -40°C to 125°C |
| Voltage drop (initial) | Typ.: 30mV (at 10A) | Vibration resistance ⁴⁾ | 10Hz to 500Hz 176m/s ² |
| | Max.: 250mV (at 10A) | | |
| Max. continuous current ¹⁾ | 70A (at 23°C); 50A (at 85°C) | Shock resistance ⁴⁾ | 294m/s ² |
| Max. switching current | 70A | Termination | QC, PCB ⁵⁾ |
| Max. switching voltage ²⁾ | 50VDC | Construction | Wash tight, Dust protected |
| Min. contact load | 1A 6VDC | Unit weight | Approx. 38g |
| Electrical endurance | See "CONTACT DATA" | Mechanical data ⁶⁾ | cover retention (pull & push): 200N min. terminal retention (pull & push): 100N min. terminal resistance to bending (front & side): 10N min. ⁷⁾ |
| Mechanical endurance | 1 x 10 ⁷ OPS (300OPS/min) | | |
| Initial insulation resistance | 100MΩ (at 500VDC) | 1) For 70A type, measured when applying 100% rated voltage on coil. | |
| Dielectric strength | 500VAC (1min, leakage current less than 1mA) | 2) For 70A type, see "Load limit curv " for details. | |
| | | 3) The value is measured when voltage drops suddenly from nominal voltage to 0 VDC and coil is not paralleled with suppression circuit. | |
| Operate time | Typ.: 6ms | 4) When energized, release time of NO contacts shall not exceed 100μs. | |
| | Max.: 10ms (at nomi. vol.) | 5) Since it is an environmental friendly product, please select lead-free solder when welding. The recommended soldering temperature and time is 240°C to 260°C, 2s to 5s. | |
| Release time | Typ.: 4ms | 6) Only valid for QC version. | |
| | Max.: 7ms ³⁾ | 7) Test point is at 2mm away from terminal end, and after removing testing force, the terminal transfiguration shall not exceed 0.5mm. | |

CONTACT DATA ⁴⁾

| Load voltage | Load type | | Load current A | On/Off ratio | | Electrical endurance OPS | Contact material | Load wiring diagram ³⁾ | Ambient temp. |
|------------------|--------------------|--------------------|----------------|--------------|-------|--------------------------|--------------------|-----------------------------------|-------------------------|
| | | | | On s | Off s | | | | |
| Standard 13.5VDC | Resistive | Make | 70 | 2 | 2 | 1×10 ⁵ | AgSnO ₂ | See diagram 1 | See Ambient temp. curve |
| | | Break | 70 | | | | | | |
| | Motor | Make ¹⁾ | 150 | 2 | 4 | 1×10 ⁵ | AgSnO ₂ | See diagram 2 | |
| | | Break | 50 | | | | | | |
| | Lamp ²⁾ | Make | 4×60W | 0.5 | 10 | 1×10 ⁵ | AgSnO ₂ | See diagram 3 | |
| | | Break | | | | | | | |
| Standard 27VDC | Resistive | Make | 40 | 2 | 2 | 1×10 ⁵ | AgSnO ₂ | See diagram 1 | |
| | | Break | 40 | | | | | | |



HONGFA RELAY

ISO9001, ISO/TS16949, ISO14001, OHSAS18001, IECQ QC 080000 CERTIFIED

2009 Rev. 1.00

- 1) Corresponds to the peak inrush current on initial actuation (motor).
- 2) The load in the table excludes flasher. When applied in flasher, a special silver alloy (AgSnO₂) contact material should be used and the customer special code should be (170) as a suffix. Please heed the anode and cathode's request when wired, terminal 30 should connect with anode.
- 3) The load wiring diagrams are listed below:

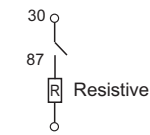

diagram 1

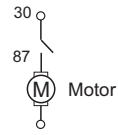

diagram 2

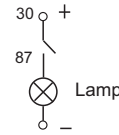

diagram 3

- 4) Loads mentioned in this chart is for relays with no parallel diode or Zener Diode. For those with parallel diode, Zener Diode or other components, please contact Hongfa for more technical supports.

Please also contact Hongfa if the actual application load is different from what mentioned above.

| COIL DATA | | | | | | | | at 23°C | |
|------------------------|---------------------|---------------------|----------------------|---------------------------|------------------------------|-------------------------|---------------------|--|---------|
| | Nominal voltage VDC | Pick-up voltage VDC | Drop-out voltage VDC | Coil resistance x(1±10%)Ω | Parallel resistance x(1±5%)Ω | Equivalent resistance Ω | Power consumption W | Max. allowable overdrive voltage ¹⁾ VDC | |
| | | | | | | | | at 23°C | at 85°C |
| Standard | 6 | 3.6 | 0.6 | 22.5 | --- | --- | 1.6 | 10 | 9 |
| | 6 | 3.6 | 0.6 | 22.5 | 180 | 20 | 1.8 | 9 | 9 |
| | 12 | 7.2 | 1.2 | 90 | --- | --- | 1.6 | 21 | 18 |
| | 12 | 7.2 | 1.2 | 90 | 680 | 79.5 | 1.8 | 18 | 18 |
| | 24 | 14.4 | 2.4 | 360 | --- | --- | 1.6 | 43 | 34 |
| | 24 | 14.4 | 2.4 | 360 | 2700 | 317.6 | 1.8 | 36 | 34 |
| High power consumption | 6 | 3.6 | 0.6 | 18 | --- | --- | 2.0 | 9 | 7 |
| | 6 | 3.6 | 0.6 | 18 | 180 | 16.4 | 2.2 | 9 | 7 |
| | 12 | 7.2 | 1.2 | 72 | --- | --- | 2.0 | 19 | 14 |
| | 12 | 7.2 | 1.2 | 72 | 680 | 65.1 | 2.2 | 18 | 14 |
| | 24 | 14.4 | 2.4 | 288 | --- | --- | 2.0 | 39 | 28 |
| | 24 | 14.4 | 2.4 | 288 | 2700 | 260.2 | 2.2 | 36 | 28 |

1) Max. allowable overdrive voltage is stated with no load applied.

ORDERING INFORMATION

| | |
|--|--|
| Type | HFV7 / 012- H 4 S P T M -R (L) (XXX) |
| | HFV7: QC type HFV7-P: PCB type |
| Coil voltage | 006: 6VDC 012: 12VDC 024: 24VDC |
| Contact arrangement | H: 1 Form A |
| Version | 4: Plastic Shrouded 6: Metal Shrouded Nil: No Shrouded |
| Construction ¹⁾ | S: Wash tight Nil: Dust protected |
| Coil power | P: High power consumption Nil: Standard |
| Contact material | T: AgSnO ₂ |
| Length of terminal | M: Short terminal & QC type 14.5mm Nil: Long terminal & QC type 17mm, or PCB type |
| Transient suppression resistor ²⁾ | R: With resistor Nil: Without resistor |
| Load type | (L): Low load type 40A (Only for 12VDC and QC type) Nil: Standard type 70A |
| Customer special code | e.g. (170) stands for flasher load |

1) Dust protected version is recommended.

2) If parallel diode, Zener Diode or other components are required, please contact Hongfa for more technical supports.

Outline Dimensions

Long terminal & QC type

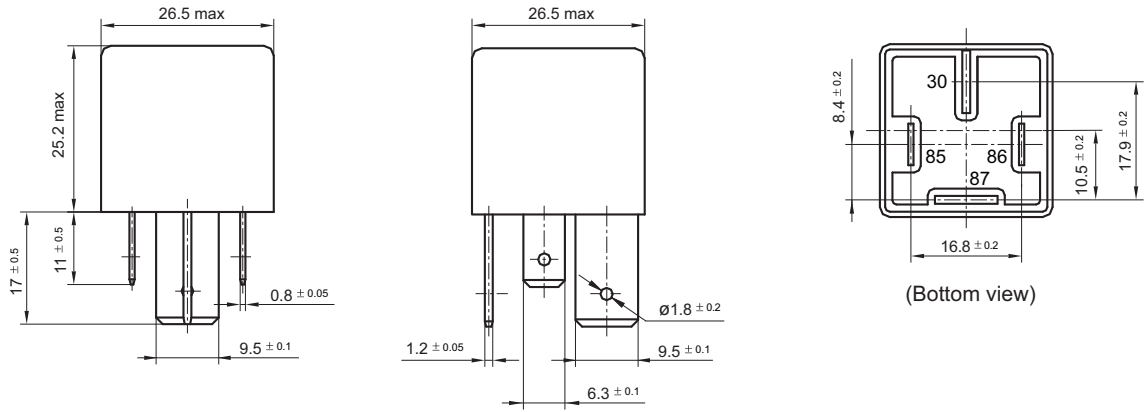

Short terminal & QC type

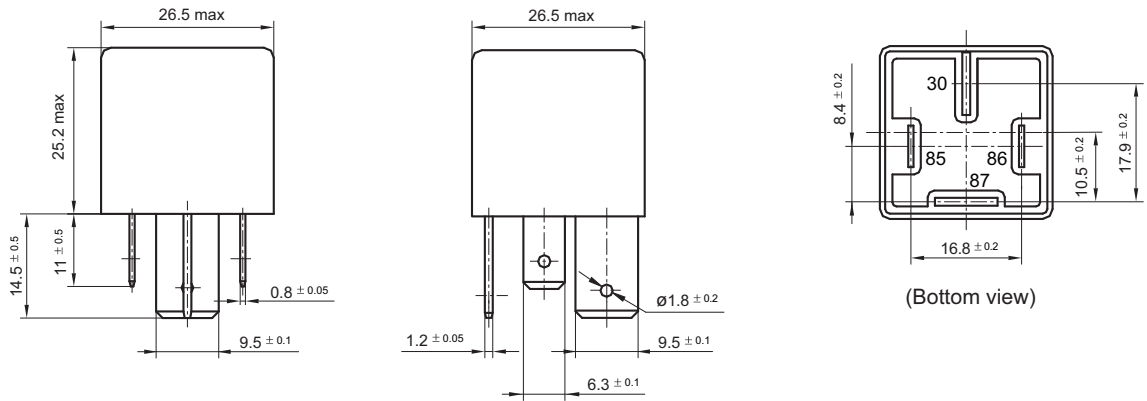

PCB type

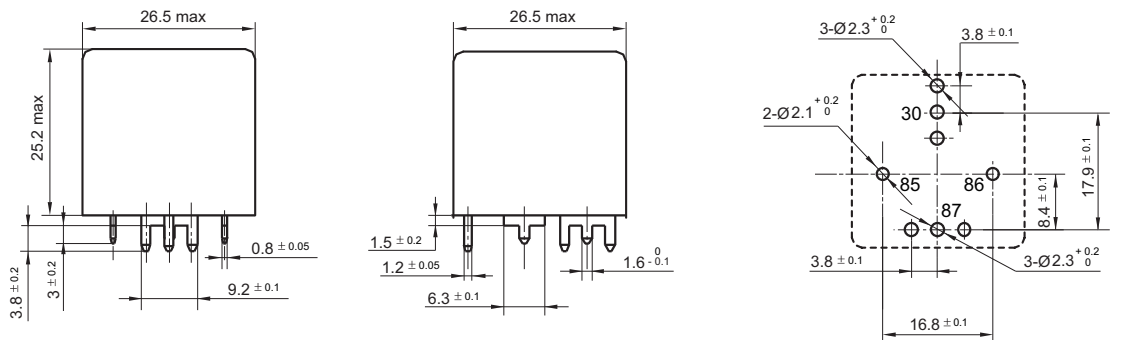

OUTLINE DIMENSIONS AND WIRING DIAGRAM

Unit: mm

Outline Dimensions

4 type: Plastic Shrouded

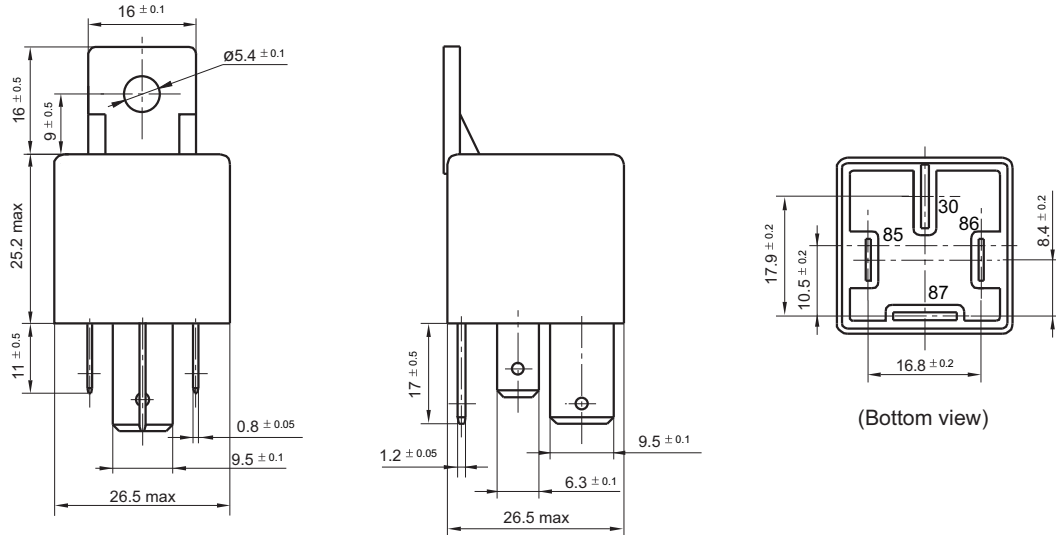

6 type: Metal Shrouded

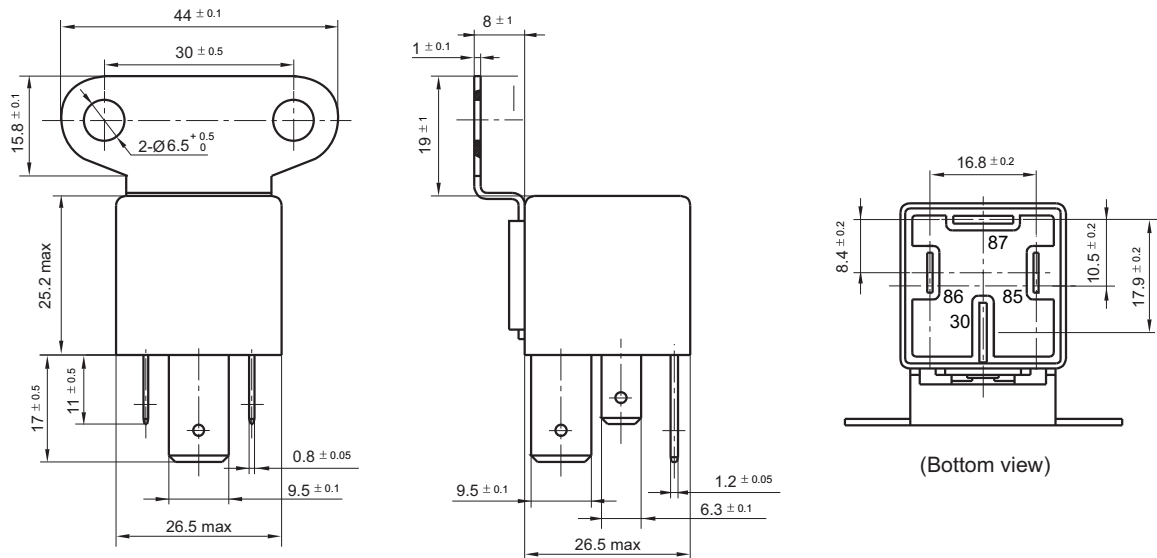

Notes: Terminal vertical deviation tolerance is 0.3mm.

Wiring Diagram

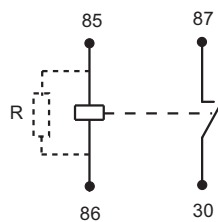

CHARACTERISTIC CURVES

1. Coil operating voltage range

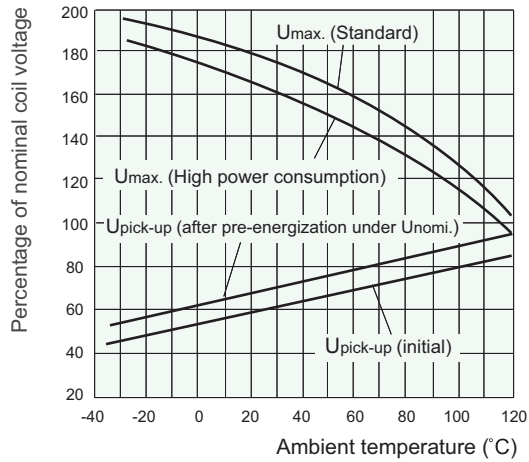

- 1) There should be no contact load applied when maximum continuous operation voltage is applied on coil.
- 2) The operating voltage is connected with coil energized time and voltage. After energized, the operating voltage will increase.
- 3) The maximum allowable coil temperature is 180°C. For the coil temperature rise which is measured by resistance is average value, we recommend the coil temperature should be below 170°C under the different application ambient, different coil voltage and different load etc.
- 4) If the actual operating coil voltage is out of the specified range, please contact Hongfa for further details.

2. Load limit curve

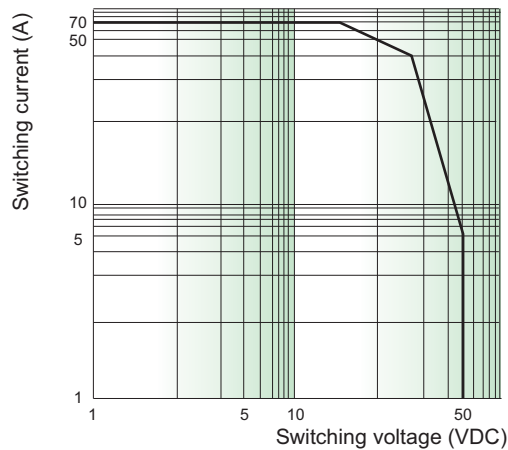

- 1) The contact load is resistive.
- 2) The load and electrical endurance tests are made according to "CONTACT DATA" parameters' table. If actual load voltage, current, or operate frequency is different from "CONTACT DATA" table, please arrange corresponding tests for confirmation.
- 3) This chart takes 70A load as example.

3. Ambient temperature curve of the electrical endurance test

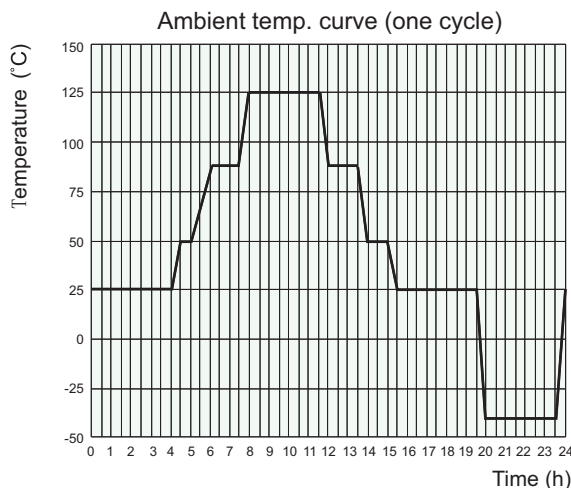

- 1) The minimum temperature is -40°C.
- 2) The maximum temperature is 125°C.

Disclaimer

This datasheet is for the customers' reference. All the specifications are subject to change without notice.

We could not evaluate all the performance and all the parameters for every possible application. Thus the user should be in a right position to choose the suitable product for their own application. If there is any query, please contact Hongfa for the technical service. However, it is the user's responsibility to determine which product should be used only.