

# User Manual

Portable thermal printer

# *s'print*



All rights reserved. Total or partial reproduction of this manual in whatever form, whether by printed or electronic means, is forbidden. While guaranteeing that the information contained in it has been carefully checked, CUSTOM ENGINEERING SPA and other entities utilized in the realization of this manual bear no responsibility for how the manual is used.

Information regarding any errors found in it or suggestions on how it could be improved are appreciated. Since products are subject to continuous check and improvement, CUSTOM ENGINEERING SPA reserves the right to make changes in information contained in this manual without prior notification.

COD. DOME-DPT100-B

Rev. 3.22

Copyright © 2001 CUSTOM ENGINEERING SPA – Italy

CUSTOM ENGINEERING SPA  
Str. Berettine 2 - 43010 Fontevivo (PARMA) - Italy  
Tel. : +39 0521-680111 - Fax : +39 0521-610701  
[http: www.custom.biz](http://www.custom.biz)

Assistenza Tecnica Clienti :  
Email : [support@custom.it](mailto:support@custom.it)

## PRINTER COMPONENTS

### A. DPT100-B – Front external view

- 1- Printer base
- 2- Cover
- 3- Paper holder
- 4- Printing mechanism
- 5- Multi-function + ON key
- 6- Paper exit slot
- 7- Infrared device

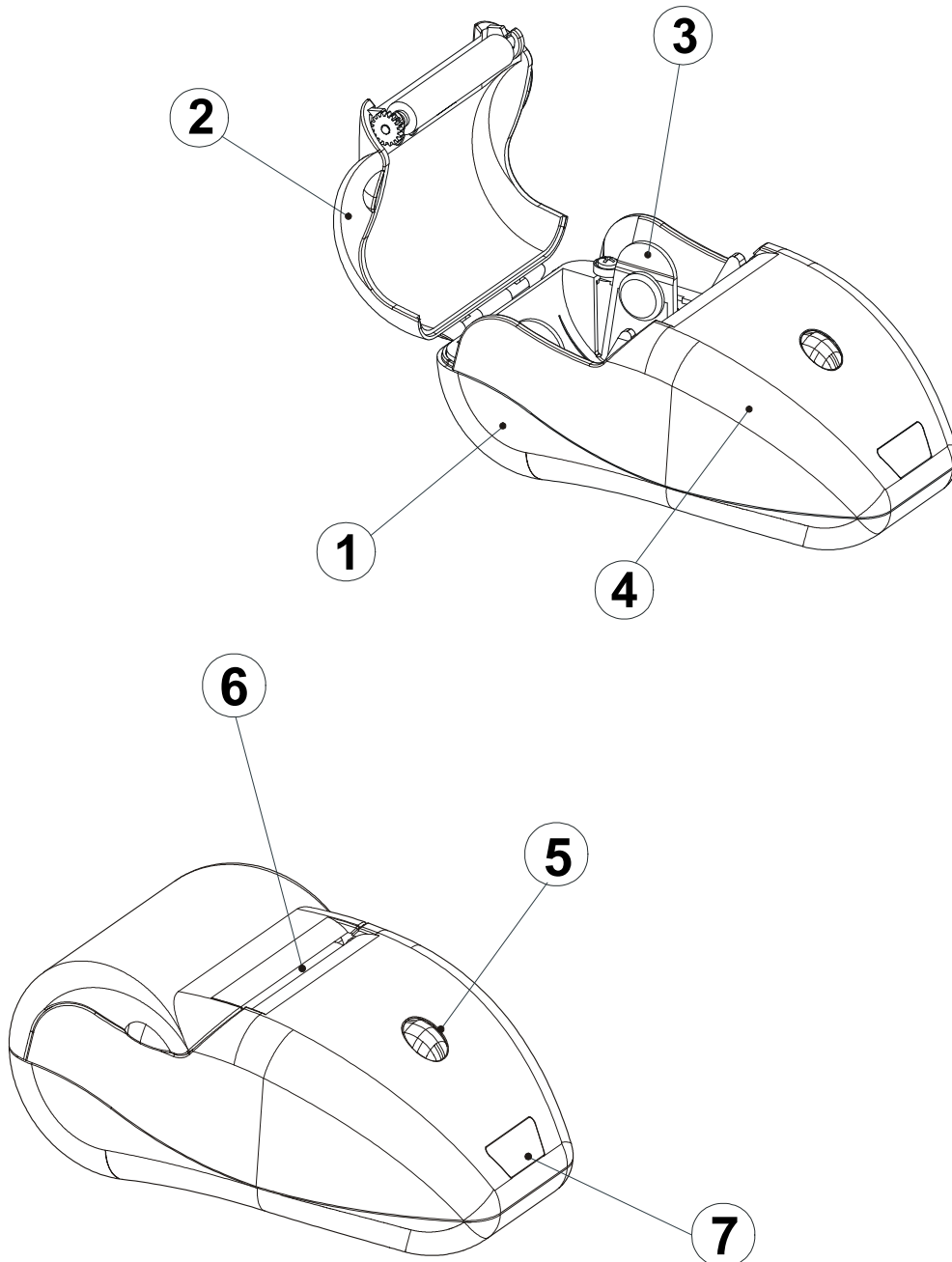

## B. DPT100-B – Under view

- 1- Serial connector and battery recharger
- 2- Battery compartment

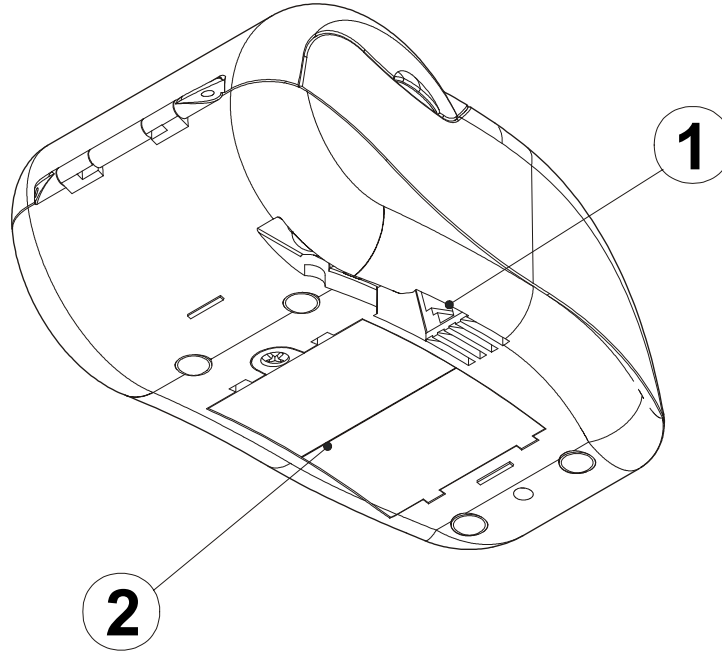

# TABLE OF CONTENTS

## INTRODUCTION

MANUAL CONTENTS .....	1
EXPLANATORY NOTES USED IN THIS MANUAL .....	1
GENERAL SAFETY INFORMATION .....	1
UNPACKING THE PRINTER .....	2
PRINTER FEATURES .....	2
PRINTER DESCRIPTION .....	3

## 1. INSTALLATION AND USE

1.1 CONNECTIONS .....	1-1
1.1.1 Battery recharger .....	1-1
1.1.2 Turning the printer On and Off .....	1-1
1.2 BATTERIES .....	1-2
1.2.1 Recharging batteries .....	1-2
1.2.2 Information regarding battery use .....	1-3
1.2.3 Replacing batteries .....	1-3
1.2.4 Disposing of batteries .....	1-5
1.3 CONFIGURATION .....	1-5
1.3.1 Configuration Mod. DPT100-B/I .....	1-5
1.3.2 Configuration Mod. DPT100-BT .....	1-6
1.4 HEXADECIMAL DUMP .....	1-8
1.5 SIXLOAD .....	1-8
1.6 MAINTENANCE .....	1-9
1.6.1 Changing the paper roll .....	1-9
1.6.2 Cleaning .....	1-10

## 2. INTERFACES

2.1 RS232 SERIAL .....	2-1
2.2 INFRARED BIDIRECTIONAL SERIAL .....	2-3
2.2.1 Standard Mode .....	2-4
2.2.2 InfraRed communication protocol .....	2-4
2.2.3 Printing instructions .....	2-5
2.3 IrDA PROTOCOL OVERVIEW .....	2-5
2.3.1 IrDA Data protocols supported .....	2-7
2.3.1.1 Physical signal layer (PHY) .....	2-7
2.3.1.2 IrLAP .....	2-8
2.3.1.3 IrLMP .....	2-8
2.3.1.4 Link Management-Information Access Service .....	2-9
2.3.1.5 IrCOMM .....	2-9
2.3.1.5.1 3-Wire Raw and IrLPT in detail .....	2-9
2.3.1.5.2 How 3-Wire Raw and IrLPT differ .....	2-9
2.3.1.5.3 IAS entry and hint bits .....	2-10
2.3.1.5.4 Basic link operation .....	2-10
2.4 BLUETOOTH PROTOCOL OVERVIEW (ONLY MOD. DPT100-BT) .....	2-10
2.4.1 Protocols supported .....	2-10
2.4.1.1 Serial Port Profile .....	2-11
2.4.1.2 Object Push Profile .....	2-11

## 3. PRINTER FUNCTIONS

3.1 CONTROL CHARACTERS .....	3-1
------------------------------	-----

**4. TECHNICAL SPECIFICATIONS**

4.1 TECHNICAL SPECIFICATIONS ..... 4-1  
4.2 ADAPTOR SPECIFICATIONS ..... 4-4  
4.3 DIMENSIONS ..... 4-5

**5. CHARACTER FONTS**

5.1 CHARACTER SETS ..... 5-1

**APPENDIX A - ACCESSORIES AND SPARE PARTS**

A.1 TICKET ALIGNMENT ..... A-1  
    A.1.1 Ticket alignment ..... A-1  
    A.1.2 Alignment Description ..... A-2  
A.2 ACCESSORIES ..... A-3  
    A.2.1 Belt coupler ..... A-3  
A.3 SPARE PARTS ..... A-3

# INTRODUCTION

## MANUAL ORGANIZATION

In addition to the Introduction which includes a description of the explanatory notes used in the manual, general safety information, how to unpack the printer and a brief description of the printer including its basic features, this manual is organized as follows:

- Chapter 1: Contains the information required for correct printer installation and its proper use, as well as interface specifications
- Chapter 2: Contains information on interface specifications
- Chapter 3: Contains a description of the printer command set
- Chapter 4: Contains Technical Specifications of the printer
- Chapter 5: Contains the character sets (fonts) used by the printer

## SYMBOL USED IN THIS MANUAL



**NOTE.** Gives important information or suggestions relative to the use of the printer.



### **WARNING**

Information marked with this symbol must be carefully followed to guard against damaging the printer.



### **DANGER**

Information marked with this symbol must be carefully followed to guard against operator injury or damage.

## GENERAL SAFETY INFORMATION

- Read and keep the instructions which follow.
- Before cleaning the printer, disconnect the power supply and make sure that the printer is off.
- Clean the printer with a damp cloth. Do not use liquid or spray products.
- Do not operate the printer near water.
- Only use approved accessories and batteries. Do not connect to products that are not compatible.
- Use the type of electrical power supply indicated on the printer label. If in doubt, contact your retailer.
- When deciding where to place the printer, make sure it is positioned where its cables will not be damaged.
- Do not introduce foreign objects of any kind into the printer as they could cause a short circuit and could jeopardize printer functioning.
- Do not spill liquids onto the printer.
- Do not carry out technical operations on the printer, with the exception of the scheduled maintenance procedures specifically indicated in the user manual.
- Disconnect the printer from the electricity supply and have it repaired by a specialized technician when:
  - A. The feed connector has been damaged.
  - B. Liquid has seeped inside of the printer.
  - C. The printer has been exposed to rain or water.
  - D. The printer is not functioning normally despite the fact that all instructions in the users manual have been followed.
  - E. The printer has been dropped and its outer casing damaged.
  - F. Printer performance is poor.
  - G. The printer is not functioning.

## UNPACKING THE PRINTER

Remove the printer from its carton being careful not to damage the packing material so that it may be re-used if the printer is to be transported in the future.

Make sure that all the components illustrated in fig. 1 are present and that there are no signs of damage. If there are, contact Customer Service.

1. Warning sheet
2. Cable
3. Paper roll
4. Adaptor / Battery recharger
5. Batteries (5 pcs.)
6. Belt coupler
7. Printer
8. Box

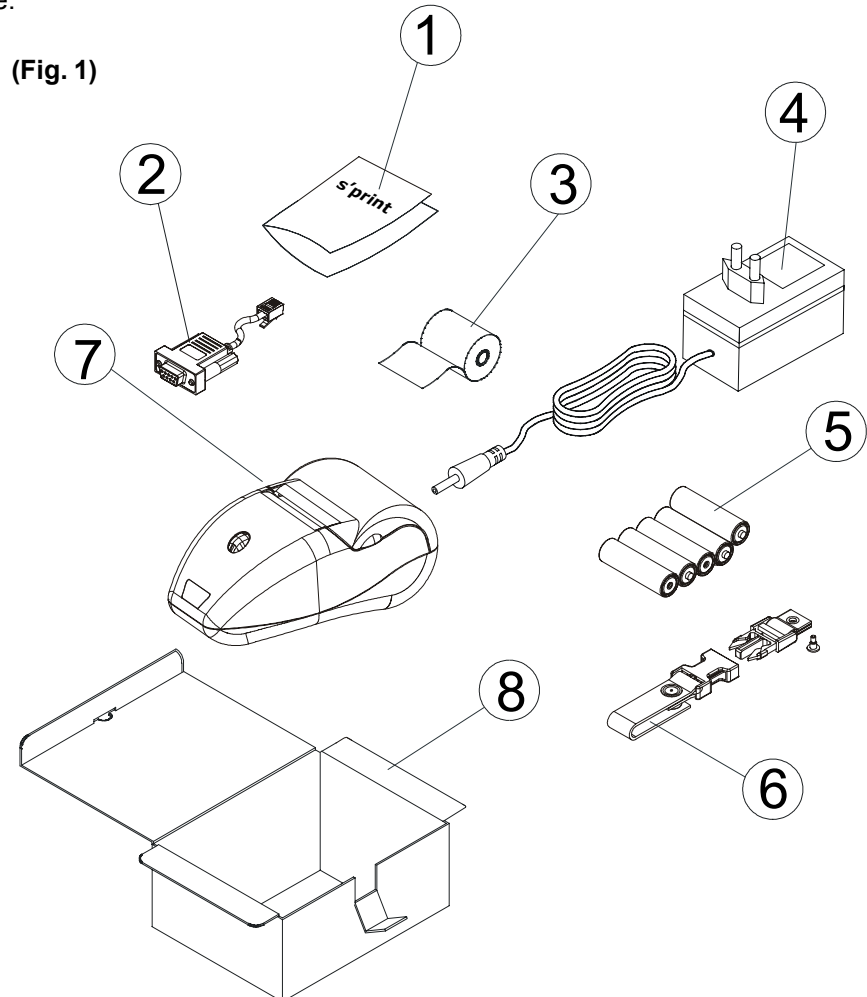

## PRINTER FEATURES

The new **s'print** portable thermal printer offers an innovative alternative to impact-based systems, with a range of interface options (RS232 serial, R232+IRDA, RS232+*Bluetooth*<sup>®</sup> wireless technology). The printer is powered using batteries.

The **battery version** (with RS232+IRDA interface) is primarily intended for the automatic identification and mobile telephony market, combined with portable terminals without printer; the infrared bidirectional interface with which it is equipped makes cable connection—so “inconvenient” for portable devices—unnecessary.

The **BT version** is powered by batteries (5 rechargeable AA penlight batteries), and communicates through RS232 serial interface and *Bluetooth*<sup>®</sup> wireless technology. s'print-BT is a light weight and slim printer. By means of the *Bluetooth*<sup>®</sup> wireless technology it is capable to print wireless at high speed without any alignment. The ideal and best match of s'print-BT is together with PDAs, mobile phones, laptop computers, and automatic ID devices.

The supported *Bluetooth*<sup>®</sup> technology profiles are SPP (Serial Port Profile) that provides RS232 serial cable emulation, and OPP (Object Push Profile) enabling the print-out of vCard format objects (business cards).

It is important to note that s'print is the first Custom printer designed with “**sixload**” easy paper load, making it simpler and more convenient to use.

It has a 203 dpi thermal print mechanism that utilizes 57.5mm-wide paper rolls and can print up to 24 or 40<sup>(1)</sup> characters per line.

# INTRODUCTION



<sup>(1)</sup>**NOTE:** The 40 column version is downloadable on the Support/Download/Firmware section from [www.custom.it](http://www.custom.it) web site.

## PRINTER DESCRIPTION

The printers consists of a ABS-V0 casing (1) equipped with a cover (2) under which is housed the paper roll and print mechanism. On the front is the multi-function key (3) and red LED (4).

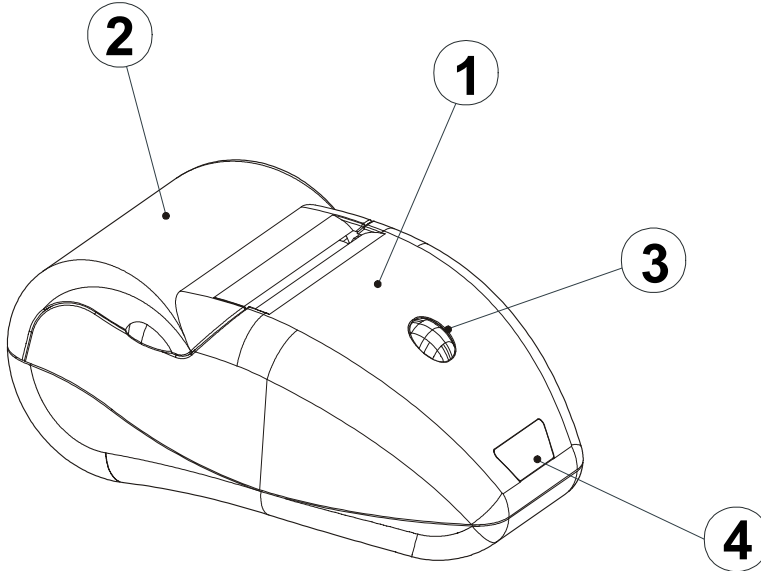

(Fig. 2)

- **Multi-function key.** This key is used to access a variety of printer options depending on how long it is held down. If the printer is off (red LED off), when this key is pressed power is turned on (blinking red LED). To turn the printer off the key is pressed two times (the LED begins to blink faster) and if it is not pressed again within three seconds the printer shuts off. During the power-up phase, if the key is held down for at least three seconds, the printer enters the configuration mode and prints out a printer setup report. When the print-out is complete, the printer remains in stand-by to receive characters from the serial interface that are printed out in hexadecimal code. If the key is pressed, the printer by-passes the setup mode and terminates the hexadecimal dump function. Pressing the key quickly will exit the configuration mode, while if it is held down for at least a second, it is possible to make changes in the individual parameters.
- The red LED displays printer operating status and this check is performed “on-line”. Table 1 lists operating statuses and the LED signals connected to them: **(Tab.1)**

LED status	Description
Always off	Printer off
Always on	Printer on - no fault with batteries recharging
Very slow blinking (one blink every three seconds)	Printer On - no fault with batteries not recharging
Slow blinking (one blink every second)	Paper Out message
Fast blinking (one blink every half second)	Resettable error (head overheating, battery voltage error)
Very fast blinking (seven blinks per second)	In process of shutting off

# 1. INSTALLATION AND USE

## 1.1 CONNECTIONS

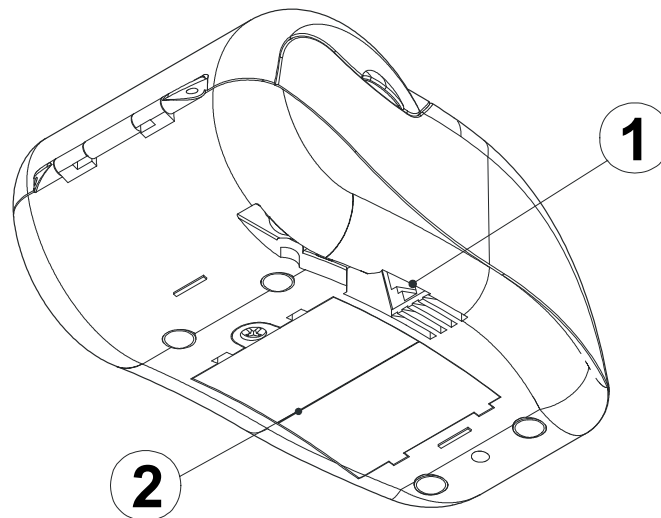

(Fig.1.1)

### 1.1.1 Battery Recharger

For the Battery Recharger/Power Supply and serial connection, the printer is equipped with a connecting cable (fig. 1.2) that comes packed with the printer and has a double connection system. On one side is a 9-pin female connector (fig. 1.2.A) for the serial port; on the other side of the same connector is a RJ11 connector (fig. 1.2.B) and a jack (fig. 1.2.C) for connection to the battery recharger.

The printer is equipped with a rechargeable battery pack, located in the battery compartment (2), self-sufficient for printing. To recharge the batteries, use the connection cable (fig. 1.2) that comes packed with the printer and following the instructions reported in the 1.2.1 paragraph.

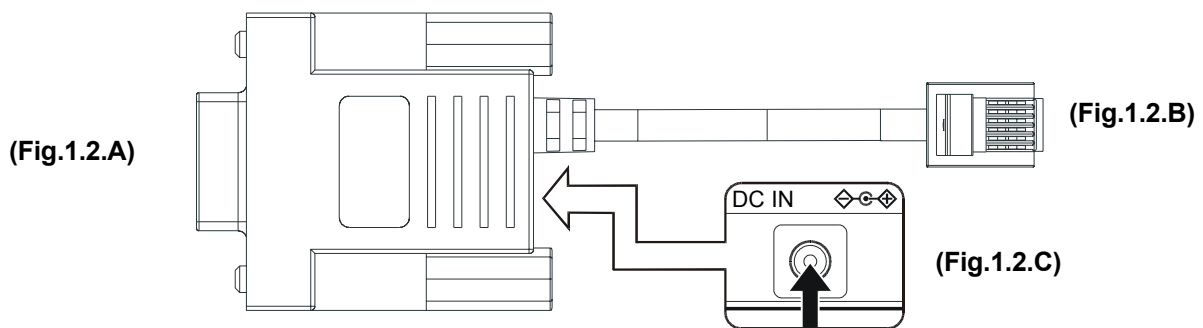

### 1.1.2 Turning the printer On and Off

#### How to turn the printer On

- by briefly pressing the multi-function key
- by sending a characters set on the serial line—it is better to send characters that are not read as printer controls (ex. 0x0E)
- with the battery recharger connected

#### How to turn the printer Off <sup>(1)</sup>

- by briefly pressing the multi-function key
- by sending the character ESC 0 over the serial line
- following a given period of inactivity as specified in setup (see sec. 1.3)

 <sup>(1)</sup> **NOTE:** If the printer is connected to the battery recharger and it recharging the batteries it's not possible to turn off the printer. It must wait that the operation in terminated.

# 1. INSTALLATION AND USE

## Turning the printer On and Off using software commands

If the printer is off, sending a characters set on the serial line will turn it on <sup>(2)(3)</sup>. Follow the instructions shown in the diagram below:



### (2) NOTE

It's not possible to turn on the printer sending one or more characters through the infrared device.



### (3) NOTE

The printer start up will not occur before 200-250 msec. This delay is caused by internal component.

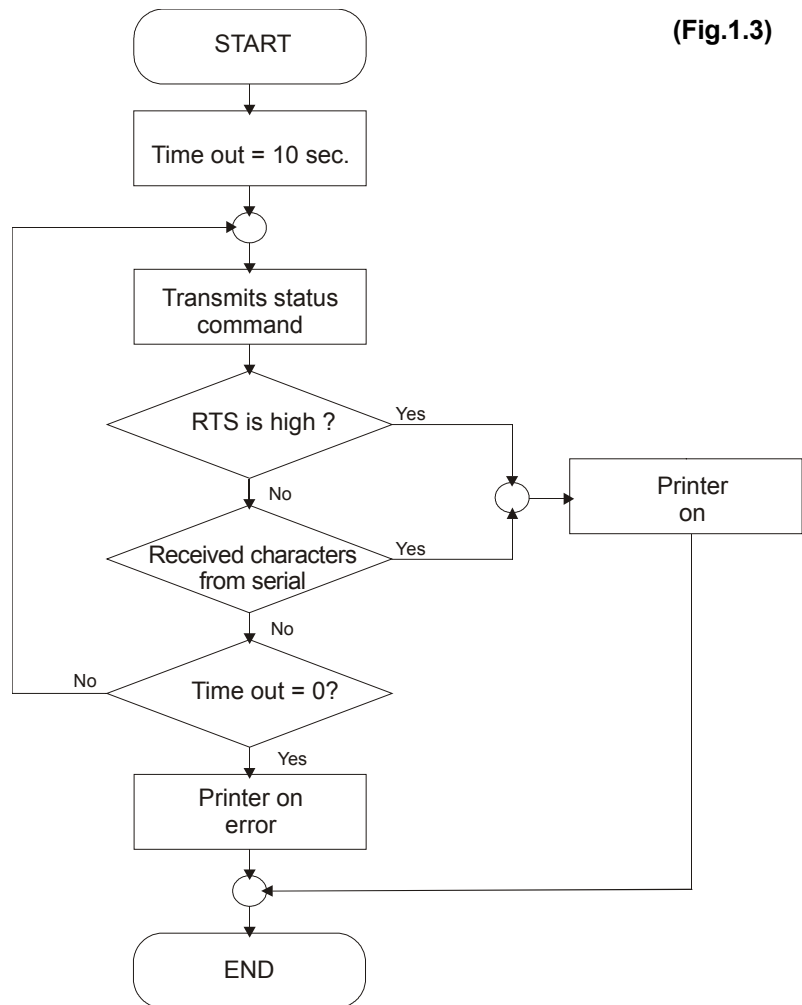

## 1.2 BATTERIES

### 1.2.1 Recharging batteries

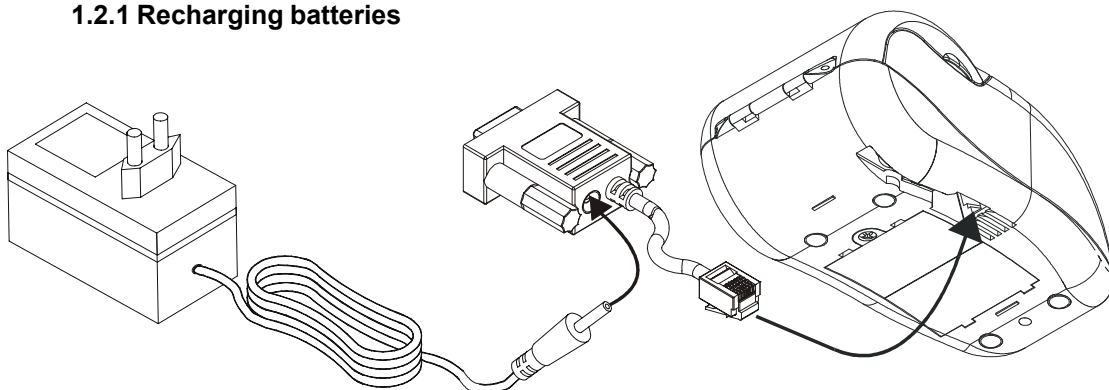

(Fig.1.4)

Appearing in the printer set up print out (see sec. 1.3) is the parameter HEAD VOLT that gives the battery charge level.

To recharge the batteries<sup>(4)</sup>, use the cable packed with the printer and proceed as follows:

- connect the battery recharger jack to the cable jack (vedi fig. 1.4) and plug the battery recharger into the electrical mains;
- connect the cable RJ11 connector to the RJ11 connector located under the printer (see fig. 1.4). For a complete recharge, we recommend that the batteries be left to charge for two hours;

# 1. INSTALLATION AND USE



<sup>(4)</sup> **NOTE:** During the recharge operation it's not possible turning the printer off.



## WARNING

Incorrect battery recharge voltage (different from that given in tab.1.2) could seriously damage the printer.

Tables 1.1 and 1.2 provide specifications for the battery recharger

(Tab.1.1)

PIN	SIGNAL	IN / OUT	DESCRIPTION
1	+ VRIC	POWER	Battery recharge
2	GND	POWER	Ground signal

(Tab.1.2)

Max recharge current	0.6 A
Max recharge voltage	12V - 36V

## 1.2.2 Information regarding battery use

- Please note that the new NiMH battery reaches maximum performance levels only after having been completely discharged and recharged at least two or three times.
- Never use battery rechargers and/or batteries that are damaged or worn.
- Battery life varies greatly depending, for example, on print density and the text to be printed.
- Recharge times vary depending on depletion levels, type of battery and battery recharger used. Batteries may be recharged and discharged hundreds of times, but they do wear out over time. When battery life (both print and stand-by) is noticeably shorter than usual, it is time to buy a new battery.
- Only utilize batteries that conform to specifications and only recharge them using battery rechargers approved by CUSTOM ENGINEERING SPA.
- When the battery recharger is not in use, unplug it from the electrical mains. If not used, even a completely-charged battery will automatically discharge over time.
- NiMH batteries last longer if you remember to completely discharge them every so often.
- Extreme temperatures can affect battery charge levels—leave them to cool or warm as required.

## 1.2.3 Replacing batteries

Instead of the rechargeable battery pack supplied with the printer, 5 AA ALKALINE penlight batteries may be used<sup>(5)(6)</sup>.



<sup>(5)</sup> **Note:** if batteries other than those supplied with the printer are used, the Battery parameter in setup must be modified and the settings changed to Alkaline if Alkaline batteries are used, or the to closest reference value for other types of batteries (see sec. 1.3).



<sup>(6)</sup> **Note:** if Alkaline batteries are used it doesn't make the recharge.

To replace batteries, proceed as follows:

- remove the cover on the battery compartment (1) by unscrewing the screws (2) and, using a flat-head screwdriver, pry open at points A and B (see fig.1.5).

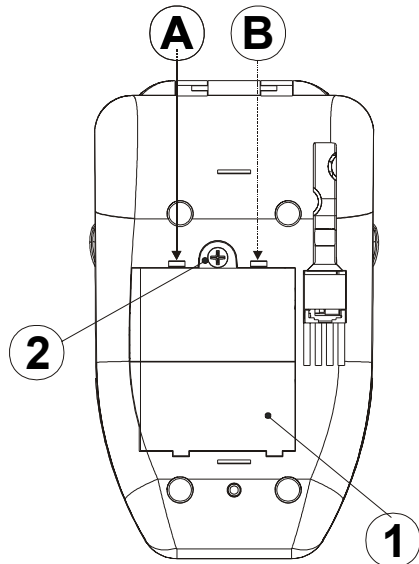

(Fig.1.5)

- remove the battery pack (2) by lifting the battery removal tape (1) (see fig. 1.6).

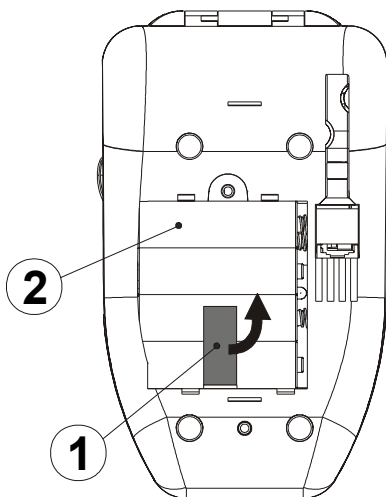

(Fig.1.6)

- insert the 5 batteries<sup>(7)</sup> inside the compartment following the layout indicated in fig. 1.7 and re-position the battery removal tape;



<sup>(7)</sup> **Note:** when inserting the batteries, make sure the + and – signs are positioned correctly.

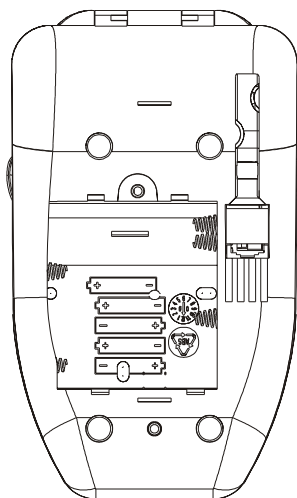

(Fig.1.7)

- reclose the battery compartment by tightening the fastening screws.

# 1. INSTALLATION AND USE

## 1.2.4 Disposing of batteries

- Batteries must be recycled or disposed of properly. Do not throw batteries away as part of normal refuse disposal.
- Do not throw batteries into open flame!

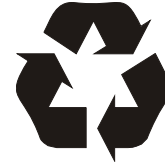

(Fig.1.8)

## 1.3 CONFIGURATION

### 1.3.1 Configuration Mod. DPT100-B/I

The printer set up print out (see fig. 1.9) includes a range of information, and among these should be pointed out the HEAD VOLT parameter that indicates the battery charge level, i.e., the print head battery voltage.

* SETUP DEFAULT *	
HEAD TEMP. [°C]	= 22.5
BATT TEMP. [°C]	= 25.0
HEAD VOLT [V]	= 6.3
Interface	:RS232
IR Protocol	:Enable
Baud Rate	:9600 bps
Data length	:8 bits/chr
Parity	:None
Handshaking	:Xon/Xoff
Autofeed	:CR disabled
Battery	:1600 mAh
Standby	:5 MIN
Alignment	:Disable
Print Density	:0

[PUSH] ENTER SET-UP  
[FAST PUSH] EXIT SET-UP

(Fig.1.9)

The printer's configurable parameters are:

- **Interface:** RS232<sup>D</sup>, Infrared<sup>(8)</sup>.
- **IR Protocol<sup>(9)</sup>:** Enable, Disable<sup>D</sup>.
- **Baud Rate:** 38400, 19200, 9600<sup>D</sup>, 4800, 2400, 1200, 600.
- **Data length:** 7, 8<sup>D</sup> bits/car.
- **Parity:** None<sup>D</sup>, even or odd.
- **Handshaking:** XON/XOFF<sup>D</sup> or Hardware<sup>(10)</sup>.
- **Autofeed:** CR deactivated<sup>D</sup> or CR activated.
- **Battery:** 1000 mAh, 1100 mAh, 1200 mAh, 1300 mAh, 1400 mAh, 1500 mAh, 1600 mAh, 1700 mAh, 1800 mAh, 1850 mAh<sup>D</sup>, Alkaline<sup>(11)</sup>.
- **Standby:** 1min, 5min<sup>D</sup>, 10 min, 30 min<sup>(12)</sup>, 1 h, 2h, None.
- **Alignment:** Disabled<sup>D</sup>, Enabled.
- **Print density:** -2, -1, 0<sup>D</sup>, +1, +2.

Please note: the parameters marked with the symbol <sup>D</sup> represent the default values.



<sup>(8)</sup> **Note:** If the Interface parameter is set in infrared and flow control is required, any time a transmission is effected a time break of one time and a half the byte transmission is needed

# 1. INSTALLATION AND USE

(for example 1.5 msec at 9600 bps). The reason is for Half Duplex type of infrared line communication. As a result the Busy condition check must be waited when transmitting data to the printer. If said condition would slow down print-out, it is alternatively possible to transmit the bytes to be printed in fixed length blocks (for example 16 bytes at a time) and to wait for the necessary time to receive a likely XON/XOFF.



<sup>(9)</sup> **Note:** The "IR Protocol" parameter is present only if interface is set in "Infrared".



<sup>(10)</sup> **Note:** It is not possible to modify the "flow control" parameter if interface is set in infrared because it is automatically set in XON/XOFF.



<sup>(11)</sup> **Note:** This parameter regulates battery recharge time. If set to Alkaline, battery recharge is disabled. If another type of battery other than those supplied with the printer is used, select the closest appropriate charge value from the list.







<sup>(12)</sup> **Note:** This parameter regulates the period of inactivity after which the printer shuts off automatically to avoid battery discharge.

Each time the key is pressed quickly, the parameter will change and the current value will be printed out. Once the desired value has been attained, hold the key down for at least a second to pass to the next parameter, and so on. Printing out of a new printer set up report indicates that set up is complete.

## 1.3.2 Configuration Mod. DPT100-BT

Printer operating status is indicated in the configuration print-out in which, next to the name of the components displayed (see figure 1.10), the following information is given:

- under  **TEST** the message OK appears if the Bluetooth communication and module are functioning and NOT OK if faulty.
- under  **NAME** is given the name that identify the printer from a Bluetooth wireless remote device.
- under  **PIN** is given the passcode used to connect to the printer *if some Bluetooth wireless devices request it.*
- under  **ADDR** is given the Bluetooth device local address; this is a fixed number assigned by the manufacturer.
- under **HEAD TEMPERATURE** is given the temperature of the head.
- under **BATTERY TEMPERATURE** is given the temperature of the battery.
- under **HEAD VOLTAGE** is given the battery charge level, i.e., the print head battery voltage.

# 1. INSTALLATION AND USE

```
SETUP DEFAULT :

[*] Test = OK
[*] NAME = S'print-BT
[*] PIN = 12345
[*] ADDR = 00:0E:6D:CE:39:8D(13)
HEAD TEMP. [°C] = 27.5
BATT TEMP. [°C] = 25
HEAD VOLT [V] = 6.2

Interface : [*] Bluetooth
[*] Name ID : NO ID
Authenticat : Enabled
Obj Push Pr : Enabled(13)
Autofeed : CR Disabled
Battery : 1700 mAh
Standby : 5 MIN
Print mode : Normal
Alignment : Disabled(14)
Print Density: 0

[PUSH] ENTER SETUP
[FAST PUSH] EXIT SETUP
```

(Fig.1.10)



<sup>(13)</sup> **Note:** These parameters listed in the setup, are present only from the Firmware BlueTooth release 1.02 (FW [\*]); in the previously version are not reported.



<sup>(14)</sup> **Note :** In the printer label version (s'print-LP1 model) this parameter is not indicated because the alignment is always enabled.

The printer's configurable parameters are :

- **Interface:** BlueTooth<sup>D</sup>, RS232.
- [\*] **Name ID**<sup>(15)</sup>: NO ID<sup>D</sup>, #0, #1, #2, #3, #4, #5, #6, #7, #8, #9.
- **Authentication**<sup>(16)</sup>: Enabled, Disabled<sup>D</sup>.
- **Object Push Profile**<sup>(13)</sup><sup>(17)</sup>: Enabled, Disabled<sup>D</sup>.
- **Baud Rate**<sup>(18)</sup>: 38400, 19200, 9600<sup>D</sup>, 4800, 2400, 1200, 600.
- **Data length**<sup>(18)</sup>: 7, 8<sup>D</sup> bits/car.
- **Parity**<sup>(18)</sup>: None<sup>D</sup>, Even or Odd.
- **Hanshaking**<sup>(18)</sup>: XON/XOFF<sup>D</sup> or Hardware.
- **Autofeed** : CR Disabled<sup>D</sup> or CR Enabled.
- **Battery**: 1000 mAh, 1100 mAh, 1200 mAh, 1300 mAh, 1400 mAh, 1500 mAh, 1600 mAh, 1700 mAh, 1800 mAh, 1850 mAh<sup>D</sup>, Alkaline.
- **Standby**: 1min, 5min<sup>D</sup>, 10 min, 30 min, 1 h, 2h, None.
- **Print mode**: Normal<sup>D</sup>, Reverse.
- **Alignment**<sup>(14)</sup>: Disabled<sup>D</sup>, Enabled.
- **Print Density**: -2, -1, 0<sup>D</sup>, +1, +2.

Please note: The parameters marked with the symbol<sup>D</sup> represent the default values.

**If Bluetooth interface is enabled, it's better do not send data on RS232 line, because data could overlap Bluetooth wireless line.**

# 1. INSTALLATION AND USE



<sup>(15)</sup> **NOTE:** The  **Name ID** is used to diversify one printers from another that have the same name, inside the same area. The index will be added at the end of the name (example: S'print-BT #1). It's possible that some Bluetooth wireless remote device don't update immediately printer name, but only at the beginning of new connection. This happened because most of remote devices create a relation table between Bluetooth device address (that is passed on every access) and the identification name. So the method of research of remote devices is sensibly faster, but it involves that the printer name (or others devices Bluetooth) is update only sometimes, for the most part it happened at the beginning of new connection.



<sup>(16)</sup> **NOTE:** The authentication is used to enable the password entry, from the host at every connection, for printing. If someone is enabled to use the printer (and consequently to know the link key), can execute an operation of "pairing". When the printer is "paired" with the host, it's possible to access to printing service without re-enter the password.



<sup>(17)</sup> **NOTE:** The Object Push Profile provides facilities for exchanging business card between client and server, for pulling business card from a server, and for pushing a limited range of objects onto a server; for example, a virtual business card wich fit the vCard object format.



<sup>(18)</sup> **NOTE:** This parameter is present only if RS232 interface is set.

The " **Name**", " **PIN**", " **Name ID**" and the "**Authentication**" values become actives only turning off and then turning on the printer; reset commands or reset after set up don't get actives those setting.

## 1.4 HEXADECIMAL DUMP

This function is used to display the characters received from the communications port; after the reception of each 6 characters from the communications port, the printer prints out both the hexadecimal code received as well as the corresponding ASCII code.

Shown below is an example of a Hexadecimal Dump:

48	65	78	61	64	65	Hexade
63	69	6D	61	6C	20	cimal
64	75	6D	70	20	66	dump f
75	6E	63	74	69	6F	unctio
6E	20	30	31	32	33	n 0123
34	35	36	37	38	39	456789
61	62	63	64	65	66	abcdef
67	68	69	6A	6B	6C	ghijkl
6D	6E	6F	70	71	72	mnpqrs
73	74	75	76	77	78	stuvwxy
79	7A					z

## 1.5 SIXLOAD

The printer has been designed with an **easy paper load** system to improve handling and simplify use. This easy paper loading system is called "**sixload**" because when the paper is loaded into the printer, it looks like the number "6" (the roll on the bottom with the edge lifted).

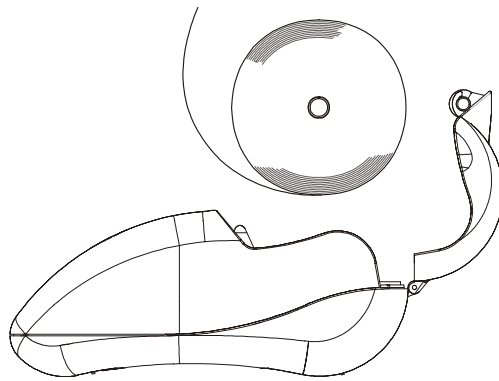

(Fig.1.11)

## 1.6 MAINTENANCE

### 1.6.1 Changing the paper roll

To change the roll of paper, proceed as follows:

- 1) Open the printer cover (see fig. 1.12) levering on the cover lateral projections and position the paper roll so that it unrolls in the direction shown in figure 1.13;

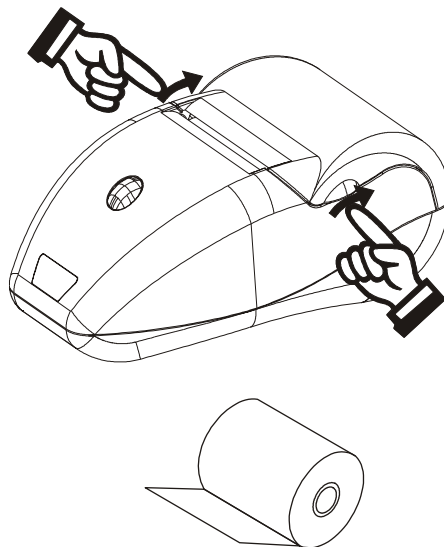

(Fig.1.12)

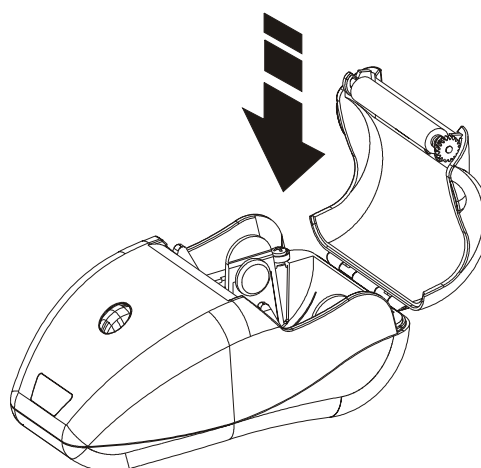

(Fig.1.13)

# 1. INSTALLATION AND USE

- 2) Pull up on the edge of the paper and close the cover (fig. 1.14);

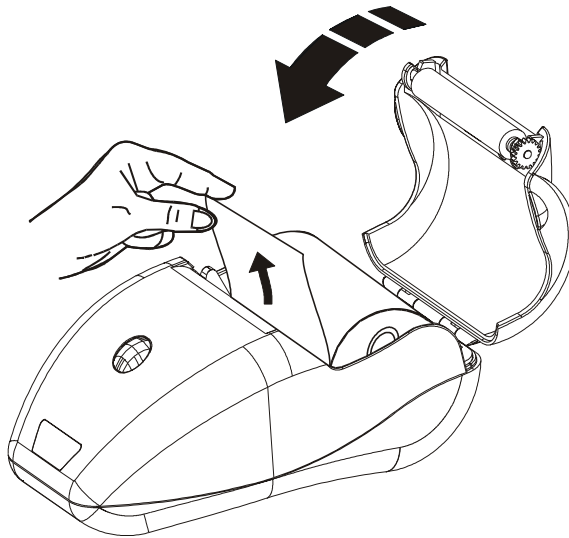

(Fig.1.14)

- 3) Tear off the paper. The printer is now ready (fig.1.15).

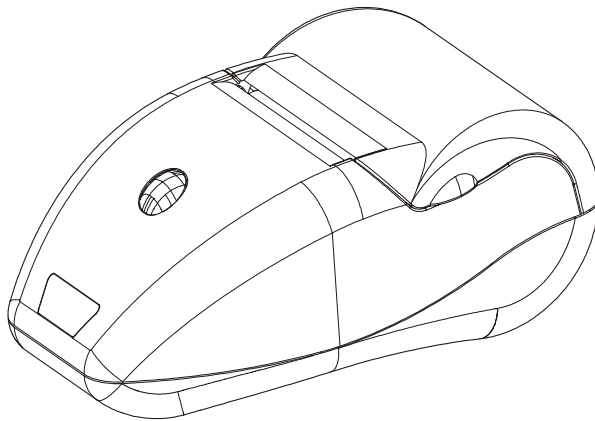

(Fig.1.15)

## 1.6.2 Cleaning

To clean the printer, use a vacuum cleaner or soft cloth.  
Before cleaning the printer, unplug its electrical cord and make sure that the printer is off.  
Do not use alcohol, solvents or hard-bristled brushes.  
Do not let water or other liquids seep into the printer.

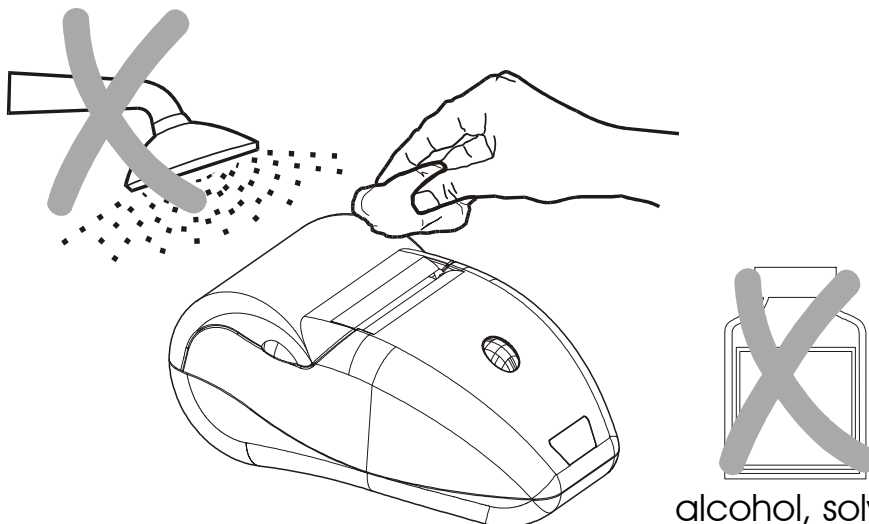

(Fig.1.16)

alcohol, solvent

## 2. INTERFACES

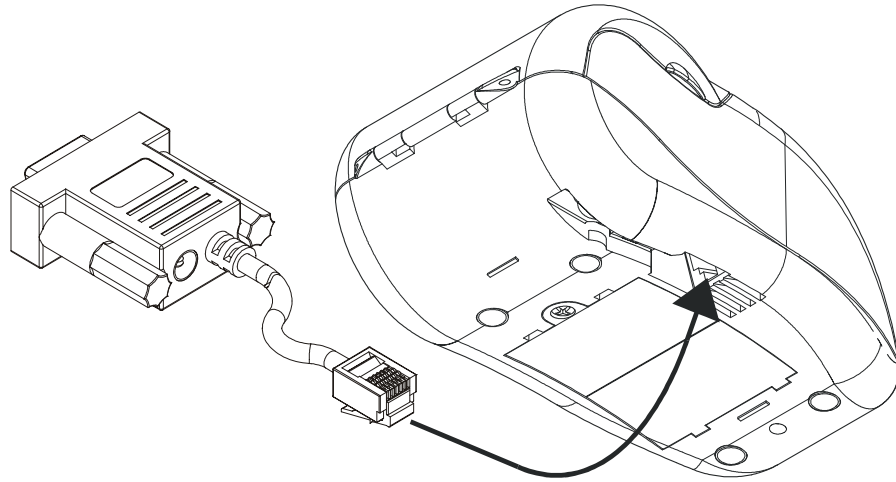

(Fig.2.1)

### 2.1 RS232 SERIAL

The printer is equipped with an RS232 serial interface with RJ11 connector (fig. 2.1) located underneath the printer. For serial connection, a connecting cable (fig. 2.2) with double connection system is packed with the printer. On one side is a 9-pin female connector (fig. 2.1.1) to connect to the serial port; on the other side of the same connector is a RJ11 connector (fig. 2.1.2).

For the layout of signals on the connectors, please refer to tables 2.1 and 2.2.

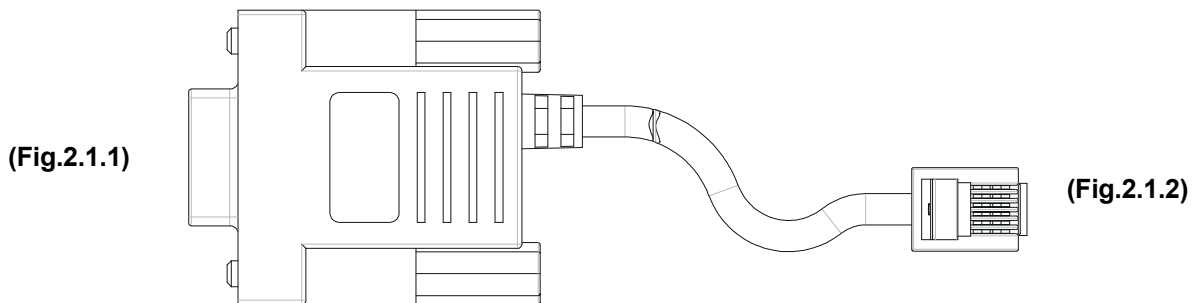

(Fig.2.1.1)

(Fig.2.1.2)

## 2. INTERFACES

RJ11 connector DPT100 (fig. 2.1)

(Tab.2.1)

PIN	SIGNAL	IN/OUT	A	DESCRIPTION
1	+VRIC	IN	-	Battery recharge voltage
2	GND	-	GND	Ground signal
3	RX	IN	TXD	Receive data
4	TX	OUT	RXD	Transmit data
5	RTS	OUT	CTS	Ready to send / Ready to receive data
6	GND	-	GND	Ground signal

9-pin female connector (fig. 2.2.A)

(Tab.2.2)

PIN	SIGNAL	IN/OUT	A	DESCRIPTION
1	DCD	OUT	DCD	Data carrier identification. Printer On (active at RS232 high)
2	TXD	OUT	RXD	Transmit data. Serial output (from host)
3	RXD	IN	TXD	Receive data. Serial data input (to host)
4	N.C.	-	N.C.	Not connected
5	GND	-	GND	Ground signal
6	DSR	OUT	DSR	Data set ready. Printer ON and operating (active at RS232 high)
7	N.C.	-	N.C.	Not connected
8	RTS	OUT	CTS	Ready to send / Ready to receive data (active at RS232 high)
9	N.C.	-	N.C.	Not connected

The diagrams below show a sample connection between printer and Personal Computer using a 9- and 25-pin female connector.

(Fig.2.2)

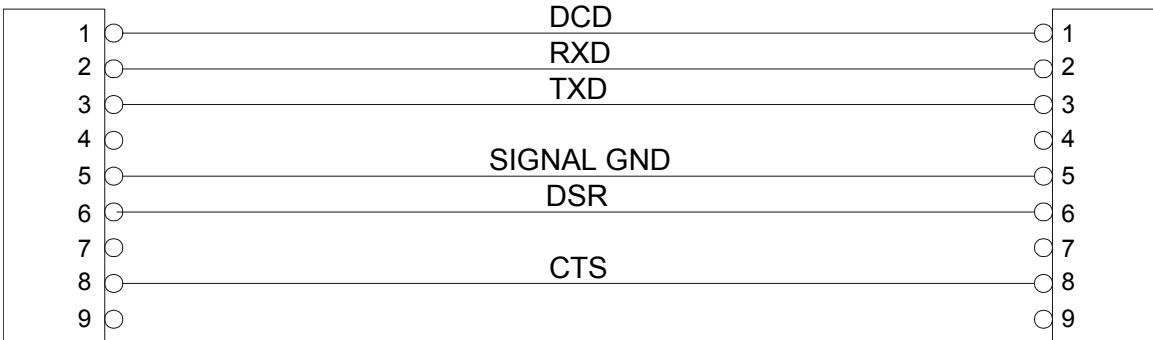

9-pin connector  
(s'print cable)

PC

## 2. INTERFACES

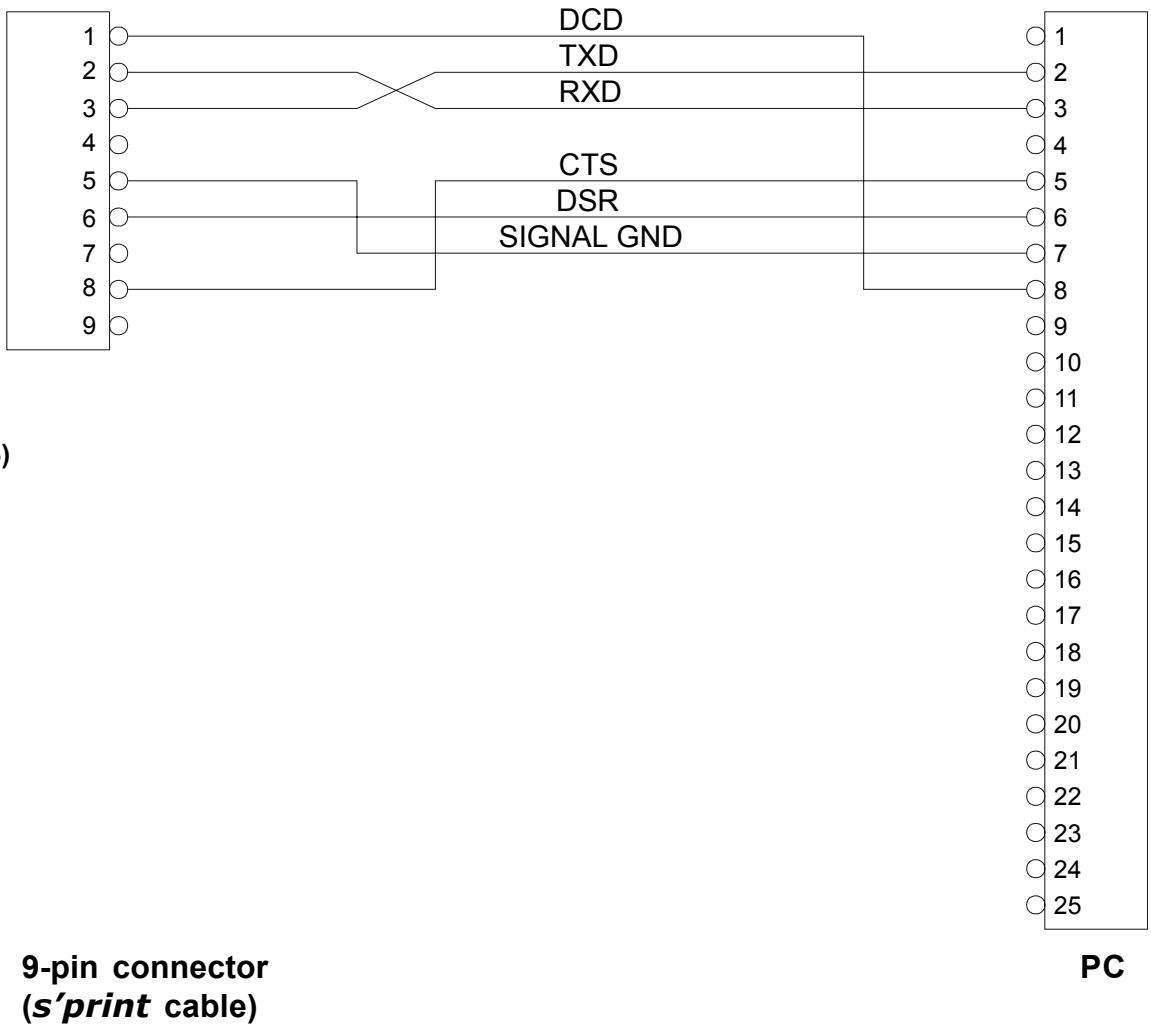

(Fig.2.3)

### 2.2 INFRARED BIDIRECTIONAL SERIAL (only DPT100-B model)

The printer has a serial interface for bidirectional data exchange. The infrared port is centered on the power part of the front (see fig. 2.4); it uses the encode method bits as described in the IrDA physical layer, for speeds up to 115.2 kbps (a 3/16th optical pulse time of bit time).

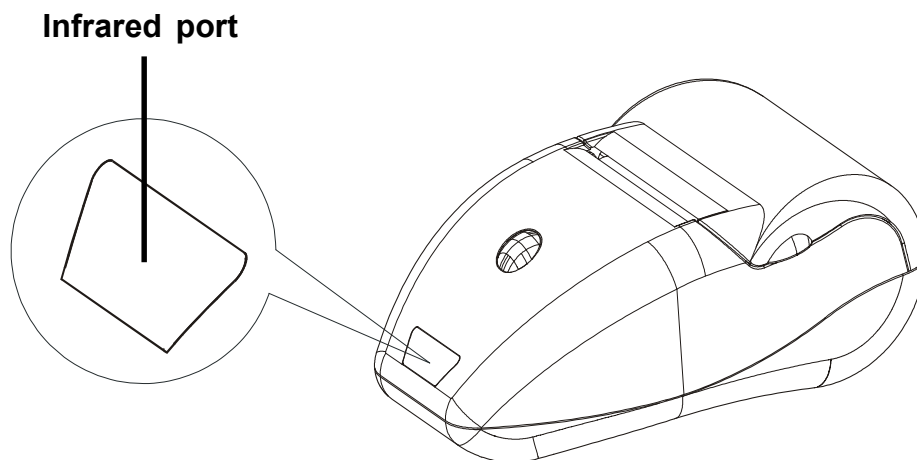

(Fig.2.4)

To utilize the infrared bidirectional serial interface, it must first be enabled under setup (parameter: "Interface: Infrared").

## 2. INTERFACES

It is possible to communicate with the printer in two different ways: by sending a string of characters and/or commands preceded by the IR port Open command and followed by a Close command (standard mode), or by utilizing a simple transfer protocol that guarantees that data is compressed correctly by the printer.

### 2.2.1 Standard Mode

To utilize the printer in standard mode, set the “IR protocol” parameter to Disabled. In this mode, the data flow to the printer must be structured as follows:

2Bytes	n Bytes	2Byte
Start Command	Data/Commands	Stop Command

**START COMMAND (\$1B \$02):** the IR port opening command, it is composed of 2 bytes with values \$1B \$02. All characters received before this command, when the communication port is closed, are ignored.

**DATA/COMMANDS:** the part of the data and/or commands the printer must elaborate and its length is variable. This field may include both data to be printed and control characters (see Section 3 “Printer Functions”). To guarantee that all data is received correctly, this field is subject to handshaking software (xon/xoff).

**STOP COMMAND (\$1B \$03):** the IR port closing command, it is composed of 2 bytes with values \$1B \$03. All characters received after this command are ignored, unless it is a START COMMAND.

EXAMPLE:

To use this protocol to print the text “CUSTOM” in double height and width, send the following data to the printer

Start command	Data							Stop command	
	Expanded mode						Line feed		
\$1B \$02	\$03	\$43	\$55	\$53	\$54	\$4F	\$4D	\$0A	\$1B \$03
		C	U	S	T	O	M		



**NOTE:** The LED is always switched on (not flashing) when using the infrared port.

### 2.2.2 InfraRed communication protocol

To utilize the IR communication protocol, the “IR Protocol” must first be set to “Enabled” under setup. The transfer protocol is structured as follows:

1Byte	1Byte	Bytes Length	1Byte	1Byte
STX	LENGTH	DATA	ID JOB	CKS

STX [1byte] = \$02 Start Transmission ID

LENGHT [1byte] = number of bytes in the transmitted data field. The maximum number of bytes to be transmitted must be <=48.

## 2. INTERFACES

- DATA** [LUNG bytes] = data to be communicated to the printer.  
The datafield may include both data to be printed and command characters (see Section 3 "Printer Functions").
- ID JOB** [1byte] = ID of the data packet received. The \$00 value of this data field is reserved. This number must be different for each transmission: a data packet with the same ID JOB as the previous data packet is formally accepted (an ACK message is transmitted), but it is not interpreted by the printer.
- CKS** [1byte] = Check sum of the transmitted bytes: the check sum is calculated as an 8 bit sum of all previous fields (STX, LUNG, DATI, ID JOB)

One of three responses may be sent back to the printer: ACK, NACK and BUSY. The structure of these responses is as follows:

1Byte	1Byte	1Byte
STX	TYPE	STS

- STX** [1byte] = \$02 Start Transmission ID
- TYPE** [1byte] = Response type: ACK (\$06), NACK (\$15) and BUSY (\$13)
- STS** [1byte] = Printer status: the byte is structured like that

Bit	Off/On	Hex	Decimal	Function
0,1	Off	00	0	Cover close, paper present
	On	03	3	Cover open or paper sensor not working
2,3	Off	00	0	Paper-end sensor: Paper present
	On	0C	12	Paper-end sensor: Paper not present
4	Off	00	0	[Reserved]
5	Off	00	0	Head temperature correct
	On	20	32	Head temperature error
6	Off	00	0	Battery voltage correct
	On	40	64	Battery voltage error
7	-	-	-	[Reserved]

An ACK response is returned in the event the entire protocol was interpreted correctly and the check sum calculated is the same as that received by the host.

A NACK response is returned in the event of transmission errors that cause a discrepancy between the calculated and received check sums.

A BUSY response is returned in the event the printer does not have sufficient memory to store the transmitted data. If this response is returned, use the STS byte to find the cause that generated the BUSY condition. If there are no errors (no paper, head overheating or incorrect electrical voltage), the BUSY message has been generated because the buffer is full and it is necessary to wait for the buffer to empty; then change the IDJOB field and repeat the transmission.

EXAMPLE:

To use this protocol to print the text "CUSTOM" in double height and width, send the following data to the printer :

STX	LENGTH	Data								IDJOB	CKSUM
		Expanded mode							Line Feed		
\$02	\$08	\$03	\$43 C	\$55 U	\$53 S	\$54 T	\$4F O	\$4D M	\$0A	\$01	\$F3

### 2.2.3 Printing instructions

- 1) To use the printer's infrared port, a computer or Personal Digital Assistant (PDA) with IR port is required.
- 2) Position a computer conforming to the specifications in point 2) not more than a meter away from the printer's infrared port. Make sure the two ports are in front of each other with an angle of not more than 15° on the four sides. Send the print command from the computer (see fig.2.5).
- 3) Send the following data printing, like described in to paragraph 2.2.1 and 2.2.2 for mod. DPT100-B or like described in to paragraph 2.3 for mod. DPT100-I

(Fig.2.5)

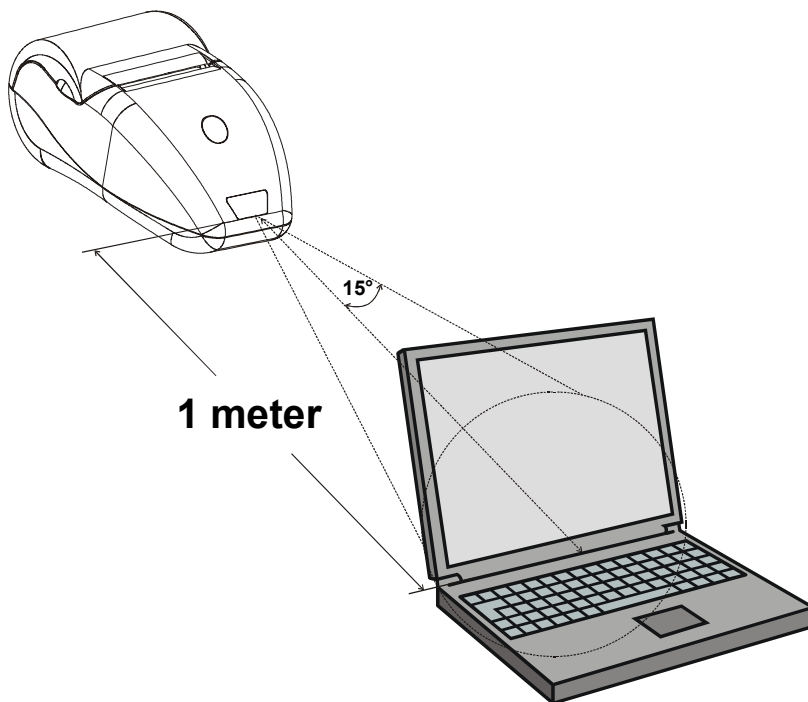

### 2.3 IrDA PROTOCOL OVERVIEW (only DPT100-I model)

This paragraph contains a general overview information about IrDA protocol implemented on the printer. For further details about the complete IrDA standard specifications are available from the IrDA website [www.IrDA.org](http://www.IrDA.org). The IrDA standard specifies the following protocols:

- Physical Signaling Layer (PHY)
- Link Access Protocol (IrLAP)
- Link Management Protocol/Information Access Service (IrLMP/IAS)

The IrDA data lists optional protocols. These are:

- Tiny TP
- IrTran-P
- IrOBEX
- IrLAN

## 2. INTERFACES

- IrCOMM
- IrMC
- IrDA Lite

Figure 2-6 shows the IrDA data protocol stack and which components are implemented by the printer.

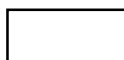
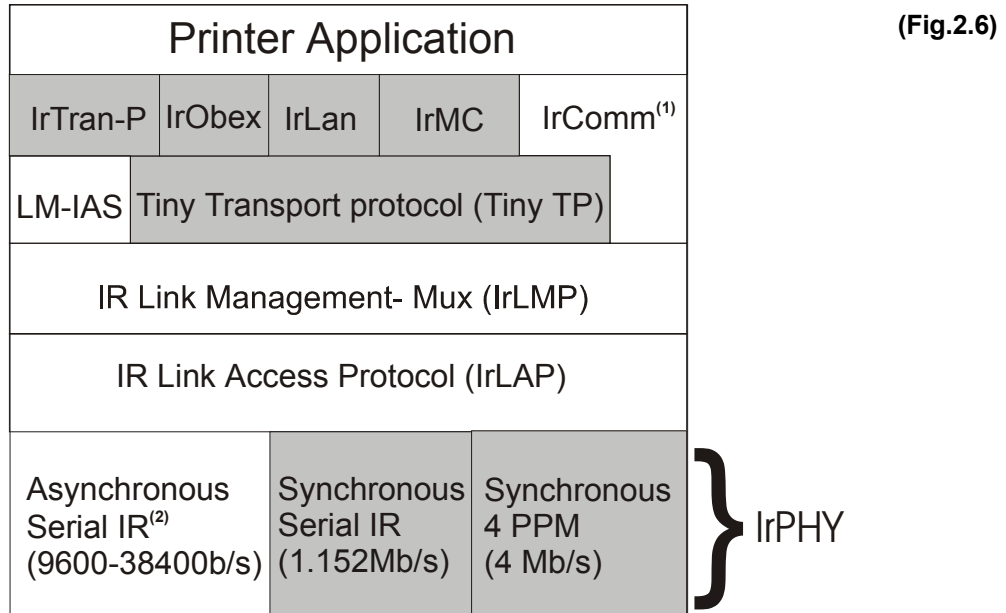

Supported by the printer



Optional IrDA data protocols not supported by the printer



**Note 1:** the printer implements the 3-wire Raw service class.

### 2.3.1 IrDA DATA PROTOCOLS SUPPORTED

The printer supports these required IrDA standard protocols:

- Physical Signaling Layer(PHY)
- Link Access Protocol(IrLAP)
- Link Management Protocol/information Access Service(IrLMP/IAS)

The printer also supports some of the optional protocols for IrDA data. The optional protocols that the printer implements are:

- IrCOMM

#### 2.3.1.1 Physical Signal Layer(PHY)

The printer provides the following Physical Signal Layer specification support:

- Bi-directional communication
- Data Packets are protected by a CRC-16-bit CRC for speeds up to 38400 kbaud
- Data communication Rate-9600 baud minimum data rate (with primary speed/cost steps of 38400 baud)
- Communication Range
- Continuous operation from contact to at least 1 meter (typically 2 meters can be reached), all the same it's possible in a low power devices reduce the distance at least 20 cm.

### 2.3.1.2 IrLAP

The IrLAP protocol provides:

- Management of communication processes on the link between devices.
- A device-to-device connection for the reliable, ordered transfer of data.
- Device discover procedures.
- Hidden node handling.

Figure 2-6 identifies the key parts and hierarchy of the IrDA protocols. The bottom layer is the Physical layer, IrPHY. This is the part that converts the serial data to and from pulses of IR light. IR transceivers can't transmit and receive at the same time. The receiver has to wait for the transmitter to finish sending. This is sometimes referred to as a "Half-Duplex" connection. The IR Link Access Protocol (IrLAP) provides the structure for packets or "frames" of data to emulate data that would normally be free to stream back and forth.

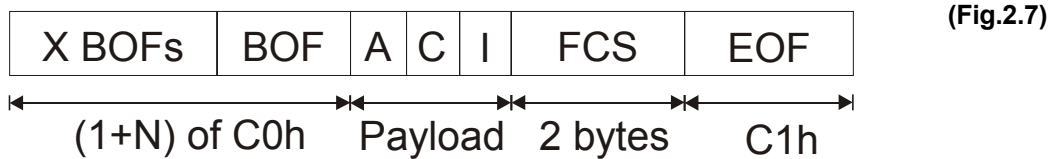

Figure 2-7 shows how the IrLAP frame is organized. The frame is preceded by some number of Beginning of frame characters, (BOFs). The value of the BOF is generally \$C0, but 0xFF may be used if the last BOF character is a \$C0. The purpose of multiple BOFs is to give the other station some warning that a frame is coming.

The IrLAP frame begins with an address byte ("A" field), then a control byte ("C" field). The control byte is used to differentiate between different types of frames and is also used to count frames. Frames can carry status, data, or commands. The IrLAP protocol has a command syntax of its own, and these commands are part of the control byte. Lastly, IrLAP frames carry data. This data is the information or "I" field. The integrity of the frame is ensured with a 16-bit CRC, referred to as the Frame Check Sequence (FCS). The end of the frame is marked with an EOF character which is always a \$C1. The frame structure described here is used for all versions of IrDA protocols used for serial wire replacement for speeds up to 38400 baud.

In addition to defining the frame structure, IrLAP provides the "housekeeping" function of opening and closing connections, and maintaining connections once they're open. The critical parameters that determine the performance of the link are part of this function.

These parameters control how many BOFs are used, identify the speed of the link, how fast either party may change from receiving to transmitting, etc. IrLAP has the responsibility of negotiating these parameters to the highest common set so that both sides can communicate as fast and as reliably as possible.

### 2.3.1.3 IrLMP

The IrLMP protocol provides:

- Multiplexing of the IrLAP layer. This allows multiple channels above an IrLAP connection.
- Protocol and service discovery. This is via the Information Access Service (IAS).

When two devices that contain the IrDA standard feature are connected, there is generally one device that has something to do, and the other device has the resource to do it. For example, a laptop may have a job to print and an IrDA standard compatible printer has the resources to print it. In IrDA standard terminology, the laptop is a Primary device and the printer is the Secondary device. When these two devices connect, the Primary device must determine the capabilities of the Secondary device to determine if the Secondary device is capable of doing the job. This determination is made by

the Primary device asking the Secondary device a series of questions. Depending on the answers to these questions the Primary device may or may not elect to connect to the Secondary device.

The queries from the Primary device are carried to the Secondary device using IrLMP. The responses to these queries can be found in the Information Access Service (IAS) of the Secondary device.

The IAS is a list of the resources of the Secondary device. The Primary device compares the IAS responses with its requirements and then makes the decision if a connection should be made.

## 2. INTERFACES

### 2.3.1.4 Link Management-Information Access Service (LM-IAS)

Each LM-IAS entity maintains an information data base to provide:

- Information on service for other devices that contain the IrDA standard feature (Discovery)
- Information on service for the device itself
- Remote accessing of another device's information base

This is required so that clients on a remote device can find configuration information needed to access a service.

### 2.3.1.5 IrCOMM

IrCOMM provides the method to support serial and parallel port emulation. This is useful for legacy COM applications, such as printers and modem devices.

The IrCOMM standard is simply a syntax that allows the primary device to consider the Secondary device as a serial device. IrCOMM allows for emulation of serial or parallel (printer) connections of various capabilities. The printer supports the 3-wire Raw service class of IrCOMM and IrLPT. Other service classes supported by IrCOMM are shown in Figure 2-8.

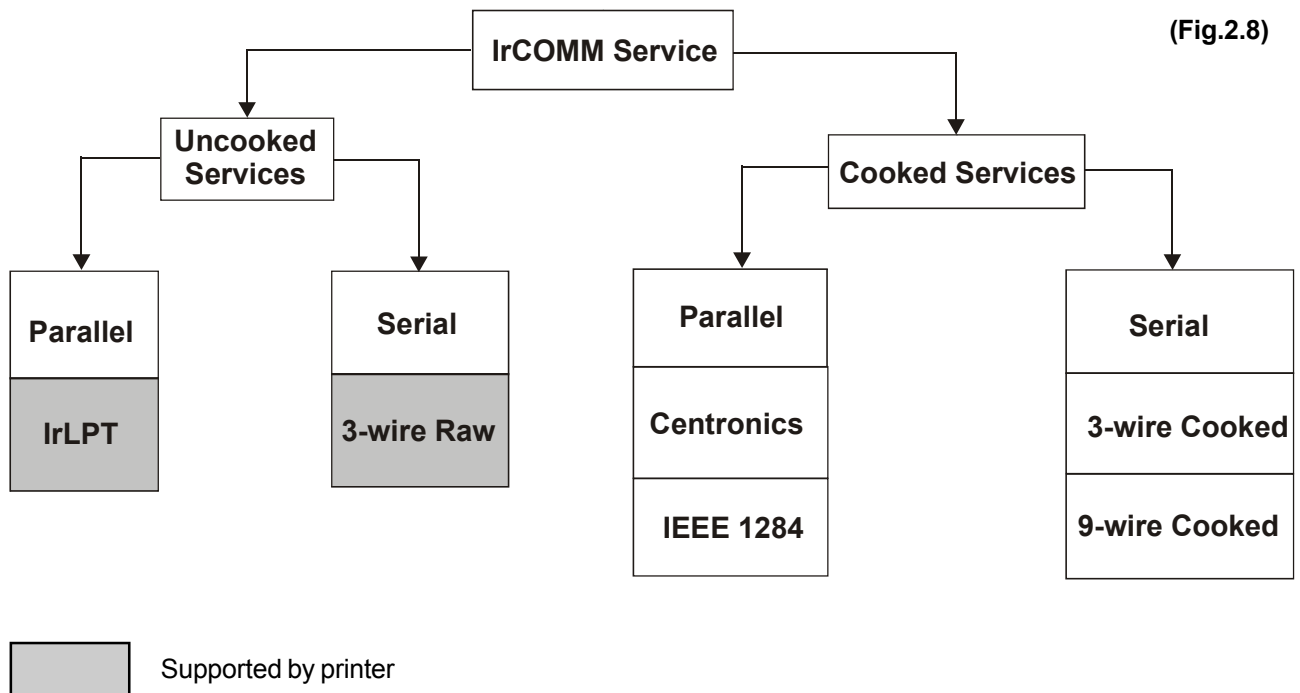

#### 2.3.1.5.1 3-Wire Raw and IrLPT in Detail

3-Wire raw and IrLPT may be used to emulate either serial or parallel ports in cases where a single exclusive connection is satisfactory. They can emulate both port types because there is no control channel, and therefore no information about the non-data circuits of either type is carried - only the data normally flowing through the data circuits is emulated. If data transfer is all a port needs to function, then 3-Wire raw or IrLPT may be fine.

#### 2.3.1.5.2 How 3-Wire raw and IrLPT differ

3-Wire raw and IrLPT are two names for the same COMM emulation service. IrLPT was built into some commercially available devices before this IrCOMM specification was complete, and is included here for compatibility. There are two differences between 3-Wire raw and IrLPT:

- IrLPT has a fixed definition and purpose - it is for printing only. IrCOMM 3-Wire raw can be used for both printing and non-printing tasks

- 3-Wire raw uses an IAS entry with classname IrDA:IrCOMM and at least two parameters. Its IAS definition may be modified or extended over time. IrLPT has classname IrLPT, only one parameter, and the IAS definition is fixed. IAS entry formats are defined in the next section. Beyond these two distinctions, 3-Wire raw and IrLPT are the same.

### 2.3.1.5.3 IAS entry and hint bits

An entity advertising 3-Wire raw must set up the IAS entry in one of two forms:

- Classname IrDA:IrCOMM with two attributes, called IrDA:IrLMP:LsapSel, and Parameters. The Parameters attribute has at least the service type parameter with at least the 3-Wire raw bit set in it.

Optionally IrDA:IrLMP:InstanceName can be used to distinguish between two instances of this service. The Discovery frame must have the IrCOMM

hint bit set. It should also have the printer bit set if this is a printing service.

- An alternate entry provided for backwards compatibility with some existing devices has Classname IrLPT with just one attribute, called IrDA: IrLMP :LsapSel. The printer hint bit must be set in the Discovery frame. This IAS object is only used for printing services.

### 2.3.1.5.4 Basic link operation

3-Wire raw connections must be exclusive - that is, all other non-IAS connections must terminate before the raw connection is made, and all others must wait until the raw connection is broken before they can connect. This is because 3-Wire raw uses IrLAP flow control, which flow controls off the entire physical link - multiple connections under this scenario could result in deadlock. At connection, the 3-Wire raw service type can be distinguished reliably by its LSAP-SEL alone, since unlike the cooked types (where multiple service types can be referenced by IrDA:TinyTP:LsapSel) only 3-Wire raw can use the LSAP-SEL specified by IrDA:IrLMP:LsapSel.

Once connected there is no control channel and no control parameters of any kind to look for - the only data that comes over 3-Wire raw is the user data that would flow over TD and RD on a serial port or the 8 data lines of a Centronics port. This means 3-Wire raw cannot be used to emulate any kind of hardware handshaking or error reporting.

## 2.4 BLUETOOTH TECHNOLOGY PROTOCOL OVERVIEW (Only mod. DPT100-BT)

In the following paragraph there is a brief description of *Bluetooth* wireless technology protocol implemented in the printer and differentiated elements that composed *Bluetooth* technology protocol.

To use the *Bluetooth* wireless communication protocol is necessary that in the set up the parameter "Interface" in "BT".

The printer is able to receive within a range of 10 m in a vacant environment.

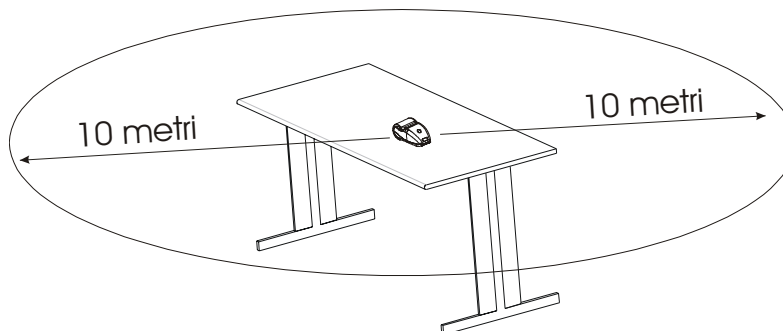

(Fig.2.9)

### 2.4.1 Supported Protocols

The figure 2.10 shows the protocols that are previews in the standard *Bluetooth* wireless technology, and the profiles that have been implemented in the printer (Object push profile e Serial port profile).

## 2. INTERFACES

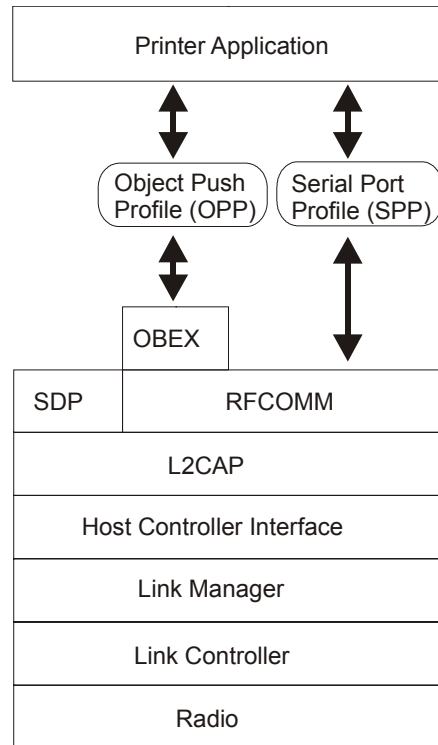

(Fig.2.10)

### 2.4.1.1 Serial Port Profile

The Serial Port Profile provides RS232 serial cable emulation for Bluetooth wireless technology devices. In this way, legacy applications do not have to be modified to use Bluetooth technology; they can simply treat Bluetooth wireless link as a serial cable link.

The Serial Port Profile uses RFCOMM to provide serial port emulation. The device which sets up the RFCOMM connection is called the initiator, while the other is referred to responder.

A few passages are requested to set the virtual serial port and to establish a connection, so it is necessary that on the side host a software management of the Bluetooth wireless technology devices must manage to execute every of these passages (the search of removed devices, the optional request of the password, channel setting RFCOMM, ecc.).

### 2.4.1.2 Object Push Profile

L'object push profile, uses the Generic Object Exchange Profile (GOEP) services that defines 2 rules: the first is a server devices that the object can be send or receive (the printer is a server devices) and a client devices that can send or receives data objects from the server (for example: a Pc, a cell Phone, or a Palm).

The Object Push Profile provides facilities for exchanging business cards between client and server, for pulling business cards from a server, and for pushing a limited range of object onto a server.

The object that printer identify are:

Object	Format	Extension
Business card	VCard	.VCF
Text File	Text	.TXT
Print file	Print on file	.PRN
Message	VMessage	.VMG
Note	VNote	.VNT
Activity object	VCalendar	.VCS

## 3. PRINTER FUNCTIONS

### 3.1 CONTROL CHARACTERS

The command table lists all the commands for the management of the printer functions. These commands can be transmitted to the printer with the serial interface. The commands can be transmitted to the printer at any moment, but they will only be carried out when the characters previously transmitted have been printed or the commands previously transmitted have been carried out. There are no commands with priority status; all the commands are carried out when the circular buffer is free to do so.

LEGEND :

Symbol	Function
\$	indicates the representation of the command hexadecimal value (for example \$40 means HEX 40).
{ }	indicates an ASCII character not performable.
n, m, t, x, y	are optional parameters that can have different values.

COMMAND TABLE

(Tab.3.1)

Com. HEX	Com. ASCII	Description
\$00	NUL	Prints in small characters
\$01	SOH	Prints in double width
\$02	STX	Prints in double height
\$03	ETX	Expanded printing
\$04	EOT	Restores small character printing
\$07	BEL	Cancel print data buffer
\$0A	LF	Forward feeds one line
\$0B (n)	VT	Forward feeds (n) line
\$0D	CR	Prints line buffer
\$0F	SI	Sets CRLF mode
\$11	DC1	Graphic mode
\$1B \$02	ESC (STX)	Enable infrared port
\$1B \$03	ESC (ETX)	Close down the communication with infrared port
\$1B \$23 n	ESC # n	Transmit printer ID
\$1B \$30	ESC 0	Turning the printer off
\$1B \$40	ESC @	Resets the printer
\$1B \$41	ESC A	Executes [n] dots line feed
\$1B \$42 m n d0...dn	ESC B m n d0...dn	Set and read BlueTooth communication parameters
(dd) \$1B \$4D	(dd) ESC M	Writes value (dd) in print mode
\$1B \$4E	ESC N	Sets normal mode printing
\$1B \$51	ESC Q	Enables underlining.
\$1B \$52	ESC R	Sets reverse mode printing.
\$1B \$57	ESC W	Print graphic line of 200 dpi.
(dd) \$1B \$61	(dd) ESC a	Selects number of dot space.
\$1B \$63	ESC c	Management of bar code printing.
\$1B \$6D	ESC m	Transmits print mode in serial.
\$1B \$71	ESC q	Disables underlining.
\$1B \$73	ESC s	Transmits next character in serial.
\$1B \$76	ESC v	Transmits printer status.
\$1B \$FA n1 n2	ESC { } n1 n2	Print graphic.
\$1D \$24 n	GS \$ n	Set absolute shift into a graphic line.
\$1D \$49 n	GS l n	Transmits printer ID.
\$1D \$55	GS U	Resets printer parameters to default value.

### 3. PRINTER FUNCTIONS

Com. HEX	Com. ASCII	Description
\$1D \$57 n d1...dn	GS W n d1...dn	Prints n byte of a 200 dpi graphic line.
\$1D \$F6 (nH) (nL)	GS { } (nH) (nL)	Aligns the ticket at the first printed line.

The following pages provide a more detailed description of each command.

#### \$00

[Name]	<b>Small character printing</b>	
[Format]	ASCII	NUL
	Hex	00
	Decimal	0
[Description]	The printer prints in small characters (normal)	
[Notes]	<ul style="list-style-type: none"> <li>• The commands \$00 - \$09 do not cancel the print buffer</li> <li>• The commands which modify the direction of the characters are only active at the beginning of the line</li> </ul>	
[Default]	Setting in option register by means of front keys	
[Reference]	<b>\$01, \$02, \$03, \$04</b>	
[Example]		

#### \$01

[Name]	<b>Double width printing</b>	
[Format]	ASCII	SOH
	Hex	01
	Decimal	1
[Description]	The printer prints in double width format	
[Notes]	<ul style="list-style-type: none"> <li>• The commands \$00 - \$09 do not cancel the print buffer</li> <li>• The commands which modify the direction of the characters are only active at the beginning of the line</li> </ul>	
[Default]	Setting in option register by means of front keys	
[Reference]	<b>\$00, \$02, \$03, \$04</b>	
[Example]		

#### \$02

[Name]	<b>Double height printing</b>	
[Format]	ASCII	STX
	Hex	02
	Decimal	2
[Description]	The printer prints in double height format	
[Notes]	<ul style="list-style-type: none"> <li>• The commands \$00 - \$09 do not cancel the print buffer</li> <li>• The commands which modify the direction of the characters are only active at the beginning of the line</li> </ul>	
[Default]	Setting in option register by means of front keys	
[Reference]	<b>\$00, \$01, \$03, \$04</b>	
[Example]		

### 3. PRINTER FUNCTIONS

#### \$03

[Name]	<b>Expanded printing</b>
[Format]	ASCII            ETX Hex                03 Decimal            3
[Description]	The printer prints in expanded character mode
[Notes]	<ul style="list-style-type: none"><li>• commands \$00 - \$09 do not cancel the print buffer</li><li>• the commands which modify the dimensions of the characters are only active at the beginning of the line</li></ul>
[Default]	Setting in the option register by means of the front keys
[Reference]	<b>\$00, \$01, \$02, \$04</b>
[Example]	

#### \$04

[Name]	<b>Restore small character printing</b>
[Format]	ASCII            EOT Hex                04 Decimal            4
[Description]	The printer resumes printing with small characters
[Notes]	<ul style="list-style-type: none"><li>• The commands \$00 - \$09 do not cancel the print buffer</li><li>• the commands which modify the dimensions of the characters are only active at the beginning of the line</li></ul>
[Default]	Setting in the option register by means of the front keys
[Reference]	<b>\$00, \$01, \$02, \$03</b>
[Example]	

#### \$07

[Name]	<b>Cancel print data buffer</b>
[Format]	ASCII            BEL Hex                07 Decimal            7
[Description]	Deletes all the print data in the current print buffer.
[Notes]	<ul style="list-style-type: none"><li>• If data that existed in the previously specified printing area also exists in the currently specified printing area, it is deleted.</li></ul>
[Default]	
[Reference]	
[Example]	

#### \$0A

[Name]	<b>Forward feeds one line</b>
[Format]	ASCII            LF Hex                0A Decimal            10
[Description]	Forward feeds one line equivalent to a line of print
[Notes]	<ul style="list-style-type: none"><li>• This command brings about the printing of the contents of the line buffer</li></ul>
[Default]	
[Reference]	<b>\$0B</b>

### 3. PRINTER FUNCTIONS

[Example]

#### (n) \$0B

[Name]	<b>Forward feeds (n) lines</b>	
[Format]	ASCII	VT
	Hex	0B
	Decimal	11
[Description]	Carries out the number of line feeds specified in (n)	
[Notes]	<ul style="list-style-type: none"><li>• The number must be ASCII and between 0 and 9 (when n=0 the command is ignored)</li><li>• This command clears the line buffer</li></ul>	
[Default]		
[Reference]	<b>\$0A</b>	
[Example]	To forward feed fast, 5 lines at a time: \$35 \$0B (or 5 and the command \$0B)	

#### \$0D

[Name]	<b>Print the line buffer</b>	
[Format]	ASCII	CR
	Hex	0D
	Decimal	13
[Description]	This command prints the line buffer	
[Notes]	<ul style="list-style-type: none"><li>• If the line buffer is empty, the command is ignored</li><li>• If the CRLF option is set, this command is ignored and printing can only be ordered through the command \$0A</li></ul>	
[Default]		
[Reference]	<b>\$0F</b>	
[Example]		

#### \$0F

[Name]	<b>Set CRLF mode</b>	
[Format]	ASCII	SI
	Hex	0F
	Decimal	15
[Description]	Inhibits the command \$0D maintaining enabled only the command \$0A for printing	
[Notes]	<ul style="list-style-type: none"><li>• To disable this option, reset the printer</li><li>• This command clears the line buffer</li><li>• On switching on the default value is in the Option Register</li></ul>	
[Default]	Setting in the option register by means of the front keys	
[Reference]	<b>\$0D</b>	
[Example]		

#### \$11

[Name]	<b>Graphic mode</b>	
[Format]	ASCII	DC1
	Hex	11
	Decimal	17

### 3. PRINTER FUNCTIONS

[Description] Enables graphic mode:  
 a line in 24 column mode corresponds to 144 horizontal dots divided into 24 blocks of 6 dots each; a line in 40 column mode corresponds to 240 horizontal dots divided into 40 blocks of 6 dots each.

[Notes] To obtain graphic printing, enter the command \$11 at the beginning of each line. The format of the byte in graphic configuration is:

**X R P6 P5 P4 P3 P2 P1**  
**D7 D6 D5 D4 D3 D2 D1 D0**

where:

**X** is not used (0 is recommended);

**R** must be fixed at level 1;

**P1, ..., P6** are the graphic dot data (1 prints, 0 does not print).

The P6 bit of the string of dots transmitted is printed on the right and the others follow from right to left (P5, P4, P3, P2, P1) as shown:

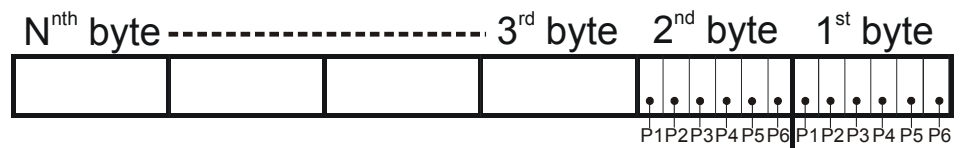

where :

n<sup>th</sup> byte = 24 for a line in 24 column mode

n<sup>th</sup> byte = 40 for a line in 40 column mode

[Default]

[Reference]

[Example]

To print a line of dots, transmit:

\$11, n x \$7F (where n is the number of characters per line), \$0D.

To print an empty line, transmit:

\$11, \$40, \$0D.

#### \$1B \$02

[Name] **Enable infrared port**

[Format] ASCII ESC (STX)  
 Hex 1B 02  
 Decimal 27 2

[Description] Enable infrared port.

[Notes] • if the printer doesn't receive this command all data sent to infrared port are ignored.  
 • After receiving this command the infrared led is always switched on.

[Default]

[Reference] \$1B \$03

[Example]

#### \$1B \$03

[Name] **Close down the communication with infrared port**

[Format] ASCII ESC (ETX)  
 Hex 1B 03  
 Decimal 27 3

[Description] Close down the communication with the infrared port .

[Notes] • The command is active only if the infrared communication channel has been enabled by the \$1B \$02 command.

### 3. PRINTER FUNCTIONS

- After the command execution the printer ignores all the characters received from the communication port until to the next \$1B \$02 reception.
- After receiving this command the infrared led is functioning, as usual.

[Default]

[Reference] \$1B \$02

[Example]

#### \$1B \$23 n

[Name] **Transmit printer ID**

[Format]

ASCII	ESC	#	n
Hex	1B	23	n
Decimal	27	73	n

[Range]  $1 \leq n \leq 3, 49 \leq n \leq 51$

[Description] Transmits the printer ID specified by *n* follows:

n	Printer ID	Specification
1, 49	Printer model ID	\$50 (24 col)
		\$54 (40 col)
		\$60 (24 col <i>Bluetooth</i> wireless technology version)
		\$61 (40 col <i>Bluetooth</i> wireless technology version)
2, 50	Not used	Fixed on \$00
3, 51	ROM version ID	Depends on version ROM (4 char)

[Notes]

- This command is executed when the data is processed in the data buffer. Therefore, there could be a time lag between command reception and data transmission, depending on data buffer status.

[Default]

[Reference]

[Example]

#### \$1B \$30

[Name] **Turning the printer off**

[Format]

ASCII	ESC	0
Hex	1B	30
Decimal	27	48

[Description] Turning the printer off.

[Notes]

[Default]

[Reference]

[Example]

#### \$1B \$40

[Name] **Resets the printer**

[Format]

ASCII	ESC	@
Hex	1B	40
Decimal	27	64

[Description] Cancels all the data in the print buffer and resets the printer mode, restoring the mode

### 3. PRINTER FUNCTIONS

which was enabled at the moment of switching on

[Notes] • Same as hardware reset  
• After the command has been transmitted, 1.5 seconds elapse before the printer is enabled

[Default]

[Reference]

[Example] This can be useful during switching on in order to avoid the sending of false characters during initialization by the master device.

#### \$1B \$41 [nH] [nL]

[Name] **Executes [n] dots line feed**

[Format]

ASCII	ESC	A	nH	nL
Hex	1B	41	nH	nL
Decimal	27	65	nH	nL

[Description] Executes [n] dots line feed.

[Notes]

[Default]

[Reference]

[Example]

#### \$1B \$42 m n d0...dn

[Name] **Sets and reads the communication Bluetooth parameters**

[Format]

ASCII	ESC	B	m	n	d0...	dn
Hex	1B	42	m	n	d0...	dn
Decimale	27	66	m	n	d0...	dn

[Range]  $1 \leq m \leq 8$   
 $0 \leq d0, dn \leq 255$

[Description] Sets and reads the parameters for Bluetooth communication ; m indicates wich operation is selected as specified below :

m	n	Operation
1	1-16	Writes the <b>BT Name</b> parameter value
2	1-8	Writes the <b>BT PIN</b> parameter value
3	1	Writes the <b>Authentication</b> parameter value
4		Writes the <b>Object Push Profile</b> parameter value
5	0	Reads the <b>BT Name</b> parameter value
6		Reads the <b>BT PIN</b> parameter value
7		Reads the <b>Authentication</b> parameter value
8		Reads the <b>Object Push Profile</b> parameter value

[Notes] • n specifies the lenght of the byte to receive and it's depends by m value;  
• d0...dn specifies the byte to store;  
• if  $1 \leq m \leq 8$  the \$06 character (ACK) is returned; otherwise the \$15 character (NACK) is returned.  
• It's recommended to entered the PINs parameter value as decimal digits because some

### 3. PRINTER FUNCTIONS

devices ( for example mobile phone), which allow PINs entered, will not support alphanumeric entry, devices sold with fixed PINs should be sold with a note of the PIN given as decimal digits.

[Default]

[Reference]

[Example]

- To reads the **BT Name** assigned to the printer send the following command :

The printer's answer is as follows (if **BT Name** is S'print BT) :

Printer	\$06	\$0B	\$53	\$27	70	\$72	\$69	\$6E	\$74	\$2D	\$42	\$54	\$00
[ASCII]	ACK	11	S	'	p	r	i	n	t	-	B	T	Null

- To set the printer's **BT PIN** parameter to '5678' send the following command :

Host	\$1B	\$42	\$02	\$05	\$35	\$36	\$37	\$38	\$00
[ASCII]	ESC	B	m	n	5	6	7	8	Null

The printer's answer is as follows :

Printer	\$06
[ASCII]	ACK

#### (dd) \$1B \$4D

[Name]

**Writes the value (dd) in the print mode**

[Format]

ASCII	dH	dL	ESC	M
Hex	dH	dL	1B	4D
Decimal	dH	dL	27	77

[Description]

Sets the print mode default parameters:

**\$00** small character printing

**\$01** double width printing

**\$02** double height printing

**\$03** expanded printing

[Notes]

- The setting is stored in the EEPROM

[Default]

Setting by means of the front keys

[Reference]

**\$1B \$6D**

[Example]

For small character printing, transmit:

\$30 \$30 \$1B \$4D

For double height printing, transmit:

\$30 \$32 \$1B \$4D

#### \$1B \$4E

[Name]

**Set normal mode printing**

[Format]

ASCII	ESC	N
Hex	1B	4E
Decimal	27	78

[Description]

Select normal mode printing:the receipt feeds out of the printer with the printing upside down running from right to left

[Notes]

[Default]

Setting in option register by means of front keys

[Reference]

**\$1B \$52**

### 3. PRINTER FUNCTIONS

[Example]

#### **\$1B \$51**

[Name]	<b>Enable underlined printing</b>		
[Format]	ASCII	ESC	Q
	Hex	1B	51
	Decimal	27	81
[Description]	After this command has been received, the characters are printed underlined		
[Note]			
[Default]			
[Reference]	<b>\$1B \$71</b>		
[Example]			

#### **\$1B \$52**

[Name]	<b>Set reverse mode printing</b>		
[Format]	ASCII	ESC	R
	Hex	1B	52
	Decimal	27	82
[Description]	Selects printing in reverse mode: the receipt feeds out of the printer with the printing in normal mode running from left to right.		
[Notes]			
[Default]	Setting in option register by means of front keys		
[Reference]	<b>\$1B \$4E</b>		
[Example]			

#### **\$1B \$57**

[Name]	<b>Prints a graphic line at 200 dpi</b>		
[Format]	ASCII	ESC	W
	Hex	1B	57
	Decimal	27	87
[Description]	After receiving this command, the printer waits for 48 bytes which correspond to an entire graphic line. In fact, 48 bytes of 8 bits each correspond to 384 dots per line.		
[Notes]			
[Default]			
[Reference]			
[Example]			

#### **(dd) \$1B \$61**

[Name]	<b>Selects the number of dot spaces</b>			
[Format]	ASCII	(dd)	ESC	a
	Hex	(dd)	1B	61
	Decimal	(dd)	27	97
[Description]	(dd) are two ASCII characters which identify a hexadecimal byte and correspond to the number of dot lines between one print line and another			
[Notes]				
[Default]	= 0			
[Reference]				

### 3. PRINTER FUNCTIONS

[Example]

#### \$1B \$63

[Name] **Management of bar code printing**  
 [Format] ASCII ESC c [code] [height] [position] [options] [length] [data]  
 Hex 1B 63  
 Decimal 27 99

[Description] This command executes a barcode printing depending on the following parameters:  
 [code] = Type of bar code (ASCII character)

VALUES:

I Interleaved 2/5  
 C Code 39  
 B CodaBar  
 e EAN8  
 E EAN13

[height] = Number of dot lines in 1/8 mm units.

[position] = Left hand margin, expressed in 1/8 mm units.

[options]

Bit 0	Function	Description
0	Check digit is not printed	Check digit
1	Check digit is printed	

Bit 1	Function	Description
-	Not used	-

Bit 3	Bit 2	Function	Description
0	0	no	HRI position
0	1	below	
1	0	above	
1	1	above and below	

Bit 5	Bit 4	Function	Description
0	0	normal	barcode width
0	1	double	
1	0	triple	
1	1	Not used	

### 3. PRINTER FUNCTIONS

Bit 1	Function	Description
6	Not used	-
7	Not used	-

[maximum length]

Interleaved 2/5 = 12 characters

Code 39 = 10 characters

CodaBar = 10 characters

EAN8 = 8 characters

EAN13 = 13 characters

[data] = Expressed in ASCII.

[Notes]

[Default]

[Reference]

[Example]

In the following example is listed the command sequence to print a barcode :

\$1B, 'N', \$1B, 'c', 'C', \$50, \$3C, \$14, \$06, 'SPRINT'



where :

\$1B, 'N' (set normal mode printing)

\$1B, 'c', (printing barcode command)

'C', ( barcode type = Code 39)

\$50, (barcode height = 10 mm)

\$3C, (starting position = 7,5 mm)

\$14, (printing HRI below, barcode width double)

\$06, (number of characters to print)

'SPRINT' (characters to print)

#### \$1B \$6D

[Name]

**Transmits the print mode in serial**

[Format]

ASCII ESC m

Hex 1B 6D

Decimal 27 109

[Description]

Transmits the print mode configuration on the serial port

[Notes]

• If the printer is using the parallel protocol, nothing will be transmitted

[Default]

Setting in the option register by means of the front keys

[Reference]

**\$1B \$4D**

[Example]

The response is on two bytes. E.g. if you receive: \$30, \$32  
it means that printing is in double height mode

### 3. PRINTER FUNCTIONS

#### \$1B \$71

[Name]	<b>Disables underlined printing</b>		
[Format]	ASCII	ESC	q
	Hex	1B	71
	Decimal	27	113
[Description]	Annuls underlined printing		
[Notes]			
[Default]			
[Reference]	<b>\$1B \$51</b>		
[Example]			

#### \$1B \$73

[Name]	<b>Transmits the next character in serial</b>		
[Format]	ASCII	ESC	s
	Hex	1B	73
	Decimal	27	115
[Description]	Transmits the next character it receives on the serial port		
[Notes]			
[Default]			
[Reference]			
[Example]	If you transmit:        \$1B \$73 \$41 the last character, \$41, will not be printed but immediately transmitted on the serial line		

#### \$1B \$FA n1 n2

[Name]	<b>Print graphic bank ( 384 × 85 dots).</b>				
[Format]	ASCII	ESC	{ }	n1	n2
	Hex	1B	FA	n1	n2
	Decimal	27	250	n1	n2
[Range]	$0 \leq n1, n2 \leq 255$				
[Description]	Prints the graphics bank from flash. <i>n1</i> specifies the starting dot line ( 1 ÷ 85 ). <i>n2</i> specifies the number of lines to print.				
[Notes]	• If $n1 + n2 > 85$ the printer only prints $85 - n1 + 1$ dotlines.				
[Default]					
[Reference]					
[Example]	To print the graphic bank from dotline 10 to dotline 40, send: \$1B \$FA \$0A \$1E				

#### \$1B \$76

[Name]	<b>Transmit paper sensor status</b>		
[Format]	ASCII	ESC	v
	Hex	1B	76
	Decimal	27	118
[Description]	When this command is received, transmit the current status of the paper sensor.		
[Notes]	• This command is executed immediately, even when the data buffer is full (Busy ). The status to be transmitted is shown in the table below:		

### 3. PRINTER FUNCTIONS

Bit	Off/On	Hex	Decimal	Function
0,1	Off	00	0	Paper sensor working properly
	On	03	3	Paper sensor not working
2,3	Off	00	0	Paper-end sensor: Paper present
	On	0C	12	Paper-end sensor: Paper not present
4	-	-	-	[Reserved]
5	Off	00	0	Head temperature correct
	On	20	32	Head temperature error
6	Off	00	0	Battery voltage correct
	On	40	64	Battery voltage error
7	-	-	-	[Reserved]

[Default]

[Reference]

[Example]

#### \$1D \$24 n

[Name] **Set absolute shift into a graphic line.**

[Format]

ASCII	GS	\$	n
Hex	1D	24	n
Decimal	29	36	n

[Range]  $0 \leq n \leq 47$

[Description] Set the print beginning position into a graphic line based on the current value of *n* that indicate the byte number of shift from left margin.

[Notes] • Settings outside the specified printable area are ignored.

[Default]

[Reference]

[Example]

#### \$1D \$49 n

[Name] **Transmit printer ID.**

[Format]

ASCII	GS	I	n
Hex	1D	49	n
Decimal	29	73	n

[Range]  $1 \leq n \leq 3, 49 \leq n \leq 51$

[Description] Transmits the printer ID specified by *n* follows:

n	Printer ID	Specification
1, 49	Printer model ID	\$50 (24 col)
		\$54 (40 col)
		\$60 (24 col <i>Bluetooth</i> wireless technology version)
		\$61 (40 col <i>Bluetooth</i> wireless technology version)
2, 50	Not used	Fixed to \$00
3, 51	ROM version ID	Depends on version ROM (4 char)

[Notes] • This command is executed when the data is processed in the data buffer. Therefore,

### 3. PRINTER FUNCTIONS

there could be a time lag between command reception and data transmission, depending on data buffer status.

[Default]

[Reference]

[Example]

#### **\$1D \$55**

[Name] **Resets the printer parameters to default.**

[Format]	ASCII	GS	U
	Hex	1D	55
	Decimal	29	85

[Description] Resets the printer parameters to the default configuration.

[Notes] • After executing this command the printer is initialized.

[Default]

[Reference]

[Example]

#### **\$1D \$57 n d1 ...dn**

[Name] **Prints n byte of a 200 dpi graphic line**

[Format]	ASCII	GS	W	n	d1...	dn
	Hex	1D	57	n	d1...	dn
	Decimal	29	87	n	d1...	dn

[Range]  $1 \leq n \leq 48$

$0 \leq d1 \dots dn \leq 255$

[Description] Print n byte of a 200 dpi graphic line where :

- n specifies the number of byte to print;
- d1...dn specify the bytes to print.

[Notes] • If the bit image data input exceeds the number of dots to be printed on a line, the excess data are processed as printable characters.  
• d indicates the bit image data. Set a corresponding bit to 1 to print a dot, or to 0 to not print the dot.  
• This command is not affected by the emphasized, double-strike, underline (etc.) print modes, except for the upside-down mode.

[Default]

[Reference]

[Example]

For printing 12 bytes the command sequence is :

`$1D $57 $0C $FF $00 $FF $00 $FF $00 $FF $00 $FF $00 $FF $00`

#### **\$1D \$F6 (nH) (nL)**

[Name] **Aligns the ticket at the first printed line**

[Format]	ASCII	GS	{ }	(nH)	(nL)
	Hex	1D	F6	(nH)	(nL)
	Decimal	29	246	(nH)	(nL)

[Description] This command searches for the reference notch on the paper and aligns the ticket at the first line to be printed.

[Note] nH and nL are the values of the shift to be made once the notch has been found

The command is only performed if alignment is enabled under setup (see parameter)

[Reference]

### 3. *PRINTER FUNCTIONS*

[Example]

To print a logo on a ticket that is 25 mm long with the hole (or notch) at the end of the ticket, the following command must be sent:

\$1D, \$F6, \$FF, \$7B                    (perform alignment)

\$1B, \$FA, \$00, \$55                    (print logo)

In this example, nH and nL are expressed in module 2 so that the motor will recede.

## 4. TECHNICAL SPECIFICATIONS

### 4.1 TECHNICAL SPECIFICATIONS

Table 4.1 gives the main technical specifications for the model DPT 100-B/I.

(Tab.4.1)

<b>Resolution</b>	203 DPI (8 dot/mm)
<b>Paper roll size</b>	57.5mm ± 1 mm
<b>Sensor</b>	Paper out
<b>Print method</b>	Thermal (8 dot/mm)
<b>Print mode</b>	Forward, reverse, 90°
<b>Print styles</b>	Normal, double height/width, reverse, underlines, expanded
<b>Character fonts</b>	1(16 x 24)
<b>Communication interfaces available</b>	RS232 / RS232 + Bidirectional infrared
<b>Drive for Windows</b>	95 / 98 / NT / W2K
<b>Baude rate</b>	da 600 a 38400 bps
<b>Print buffer</b>	128 bytes
<b>Flash memory</b>	32K
<b>Graphics memory</b>	1 logo da 384 x 85 dots
<b>Print speed</b>	Up to 50 mm/sec <sup>(2)</sup>
<b>Power suply</b>	12-36 VDC / 0.6A (Battery recharger)
<b>Batteries</b>	5 AA penlight (NI-MH/NI-CD/ALCALINE)
<b>Battery life<sup>(1)</sup></b>	100 mt of paper
<b>Autonomy (hours)</b>	
Print <sup>(1)</sup>	1 h 40 min
<b>Electric input</b>	
Print <sup>(1)</sup>	925 mA
<b>Environmental conditions</b>	
Operating temperature	0 °C ÷ 50 °C
Relative humidity	10-85 % Rh without condensing
Storage temperature / humidity	-20 °C ÷ +70 °C / 10 %Rh ÷ 90%Rh
<b>Dimension</b>	145.96mm x 88.18mm x64.61 mm
<b>Weight</b>	370 gr (without paper roll)



**Note :**<sup>(1)</sup> STANDARD CUSTOM receipt and 1300 mAh battery.

<sup>(2)</sup> It depends by the battery status, the printing typology and the environment temperature.

## 4. TECHNICAL SPECIFICATIONS

Table 4.2 gives the main technical specifications for the *Bluetooth* wireless technology model DPT 100-BT.

(Tab.4.2)

<b>Resolution</b>	203 DPI (8 dot/mm)
<b>Paper roll size</b>	57.5mm ± 1 mm
<b>Sensors</b>	Paper out
<b>Print method</b>	Thermal (8 dot/mm)
<b>Print mode</b>	Forward, reverse
<b>Print styles</b>	Normal, reverse, underlines, expanded
<b>Character fonts</b>	1(16 x 24)
<b>Communication interfaces available</b>	RS232 / Bluetooth
<b>Drive for Windows</b>	95 / 98 / NT / 2K /XP Library for print from PalmOS and PocketPC
<b>Baud rate</b>	From 1200 to 38400 bps
<b>Print buffer</b>	138 bytes
<b>Flash memory</b>	17K
<b>Graphics memory</b>	1 logo of 384 x 85 dots
<b>Print speed</b>	Up to 50 mm/sec <sup>(2)</sup>
<b>Power supply</b>	12-36 VDC / 0.6A (Battery recharger)
<b>Batteries</b>	5 AA penlight (NI-MH/NI-CD/ALCALINE)
<b>Battery life<sup>(1)</sup></b>	100 mt of paper
<b>Autonomy (hours)</b>	
Print <sup>(1)</sup>	1 h 40 min
<b>Electric input</b>	
Print <sup>(1)</sup>	925 mA
<b>Environmental conditions</b>	
Operating temperature	0 °C ÷ 50 °C
Relative humidity	10-85 % Rh without condensing
Storage temperature / humidity	-20 °C ÷ +70 °C / 10 %Rh ÷ 90%Rh
<b>Dimension</b>	145.96mm x 88.18mm x 64.61 mm
<b>Weight</b>	370 gr (without paper roll)



**Note :**<sup>(1)</sup> STANDARD CUSTOM receipt and 1300 mAh battery.

<sup>(2)</sup> It depends by the battery status, the printing typology and the environment temperature.

## 4. TECHNICAL SPECIFICATIONS

(Tab.4.3)

<b>57 mm paper</b>	<b>12.7 cpi</b>
Number of columns	24, 40 <sup>(3)</sup>
<b>Characters (L x H mm)</b>	
Normal	2 x 3
Double height	2 x 6
Double width	4 x 3
Double height and width	4 x 6

<b>Bidirectional infrared port specifications</b>	
Operating distance	up to 1mt.
Wave length	800-900 nm
<b>Bluetooth port specifications</b>	
Operating distance	up to 10 mt.
BlueTooth specification <sup>(4)</sup>	vers. 1.1
Power Class device	3
Output power	1 mW (0 dBm)
ISM Band (GHz)	2,400 - 2,4835
Lower Guard Band	2 MHz
Upper Guard Band	3.5 MHz
Available Channel	79
Modulation	GFSK (Gaussian Frequency Shift Keying)
Max Speed (Baseband)	1Mb/s
Bluetooth profile supported	SPP (Serial Port Profile) OPP (Object Push Profile)



<sup>(3)</sup>**Note:** The 40 column version is downloadable on the Support/Download/Firmware section from [www.custom.it](http://www.custom.it) web site.



<sup>(4)</sup>**Note:** Support v. 1.1 of the BlueTooth Specification.

### LED safety

The infrared port on the front of the printer conforms to Class 1 for LED devices (light-emitting diode), on the basis of international standard IEC 825-1 (EN 60825-1). This device is not considered harmful, but the following precautions should be observed:

- avoid direct exposure of eyes to infrared LED rays;
- remember that infrared rays are not visible;
- do not attempt to observe infrared LED rays with any type of optical aid.

## 4. TECHNICAL SPECIFICATIONS

### 4.2 ADAPTOR SPECIFICATIONS

#### 220Vac Adaptor

Input specifications	
Input voltage	230 Vac
Input frequency	50 Hz

Output specifications	
Output voltage	18 Vdc

(Tab.4.4)

#### 120Vac Adaptor

Input specifications	
Input voltage	230 Vac
Input frequency	50 Hz

Output specifications	
Output voltage	18 Vdc

(Tab.4.5)

## 4. TECHNICAL SPECIFICATIONS

### 4.3 DIMENSIONS

Printer dimensions are shown below.

(Fig.4.1)

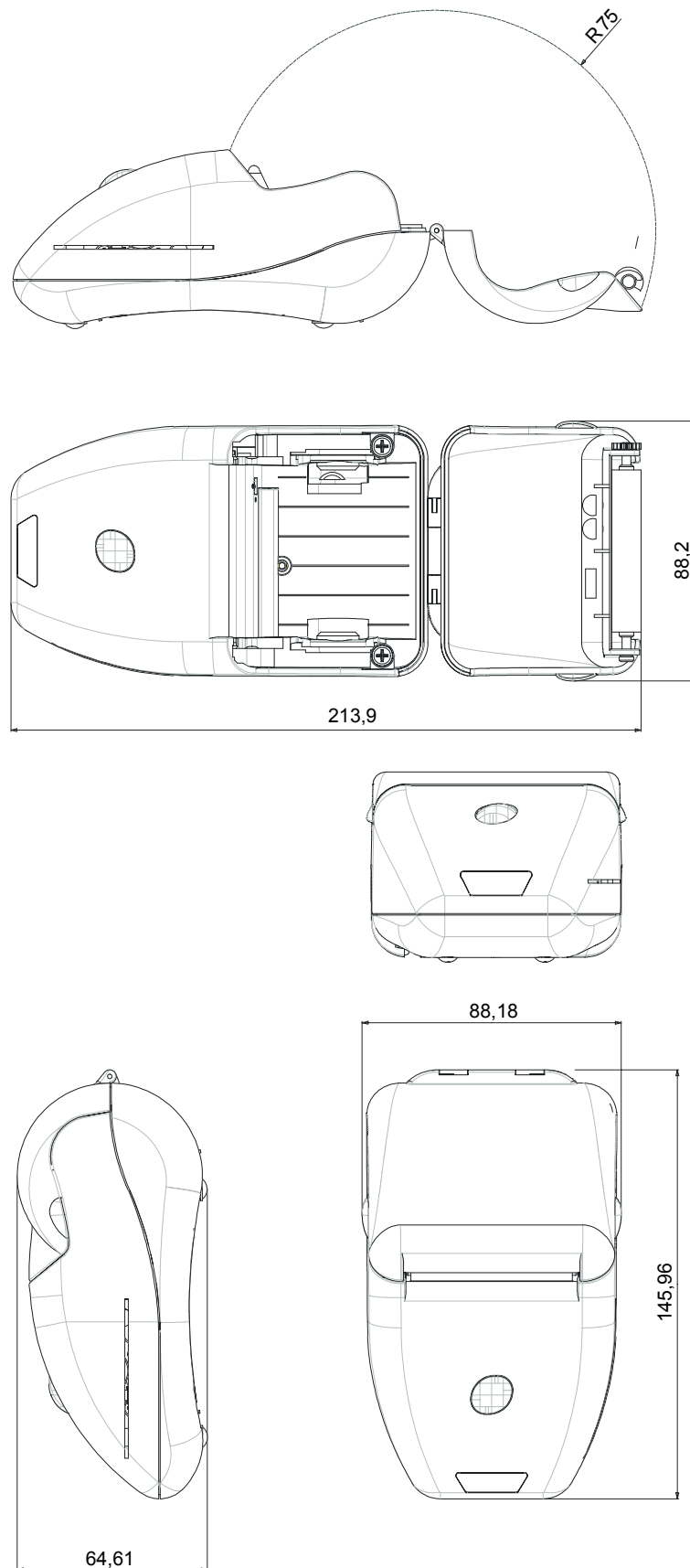

Blank page

# 5. CHARACTER SETS

## 5.1 CHARACTER SETS

The printer has a 224-character font, a print-out of which is shown below.

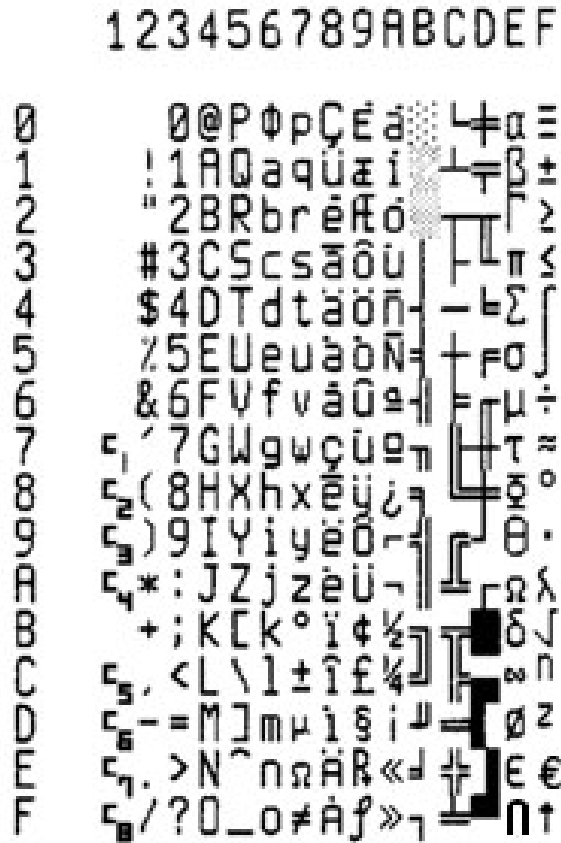

(Fig.5.1)

Blank page

# APPENDIX A - ACCESSORIES AND SPARE PARTS

## A.1 TICKET ALIGNMENT

### A.1.1 Ticket alignment

Paper stock with alignment marks is permitted so that tickets of a fixed length or with pre-printed areas may be utilized. To guarantee proper alignment, the "Alignment" parameter must be enabled under setup using the key (see: setting configuration parameters)

The notch mark must be placed on the termic side of the ticket itself (printable area); the label dimension is:

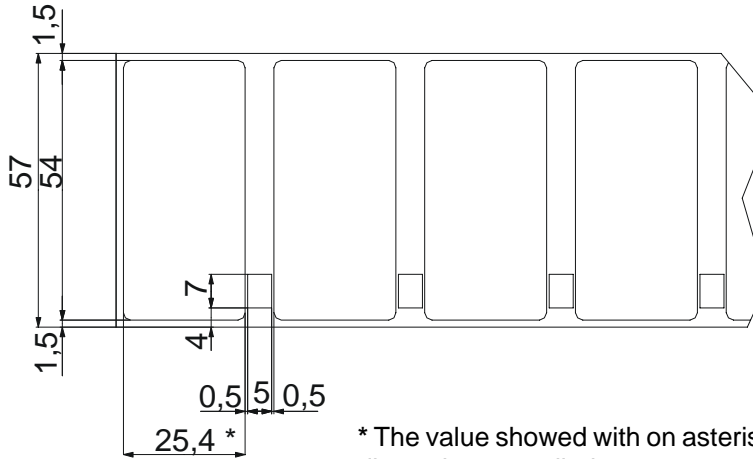

(Fig.A.1)

\* The value showed with on asterisk in the fig.A1 indicates the minium dimension controlled

#### **Applicable only for the label printer version (s' print-LP1 model) :**

Using a paper roll with the characteristics as shown in fig. A.1, pressing the multifunction key to align automatically the ticket at first printed line (see fig. A.2).

Otherwise using a different model of paper roll this additional functionality of the key is not available; to align the ticket it's necessary using a \$1D \$F6 command.

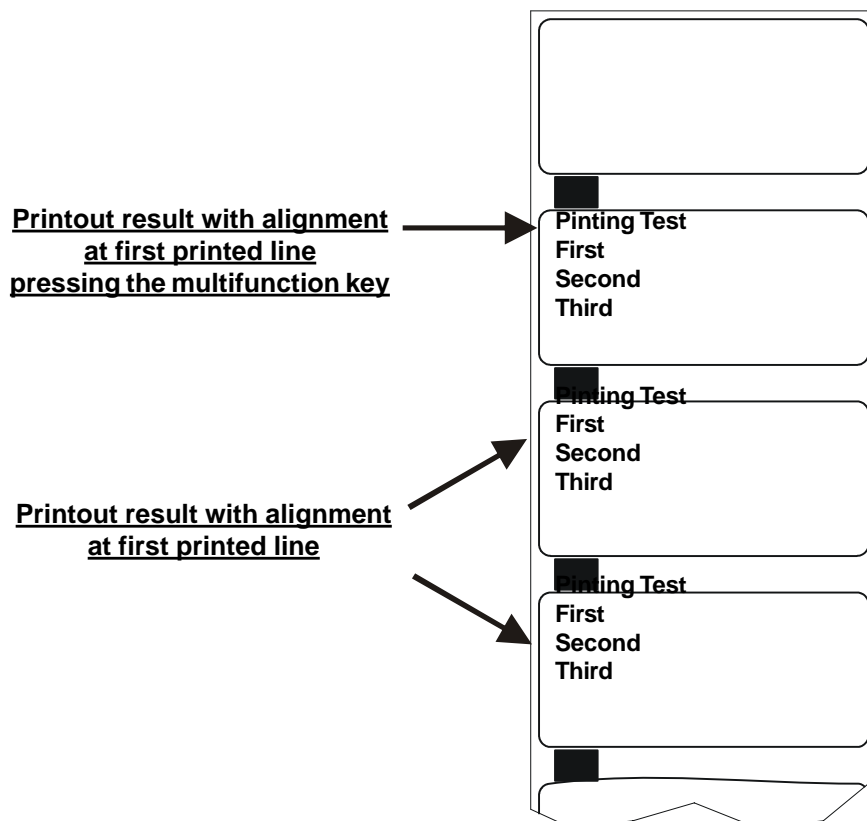

(Fig.A.2)

## A.1.2 Alignment Description

The \$1D \$F6 command searches for the reference notch on the paper and move the label with the value of nH e nL parameters. For move in the exact point for printing on the label just give the right values to parameters nH and nL.

Example: To print a logo on a ticket like in to fig.A1 with the hole (or notch) at the end of the ticket, the following command must be sent:

\$1D, \$F6, \$FF, \$7B (perform alignment)

\$1B, \$FA, \$00, \$55 (print logo)

In this example, nH and nL are expressed in module 2 so that the motor will recede.

The nH e nL parameter are calculated in the following mode:

1) Find the shift to effect, after the alignment from:

Distance =Label dimension - Distance from sensor end printing line=  
= 25.4 (mm) - 8.7 (mm) = 16.7 mm

2) Distance in dot ( express at 200 dpi ) = 16.7 (mm) \* 8 (dot/mm) = 133 dot

3) The shift is negative because the motor must be moved backwards and then should be express number in complement 2 whose corresponds to \$FF \$7B.



**NOTE:** Among printers could be a difference among alignment, these difference is dued from the sensibility of the alignment notch.

# APPENDIX A - ACCESSORIES AND SPARE PARTS

## A.2 ACCESSORIES

### A.2.1 Belt coupler

In the *s'print*-B battery model, there is a support kit available for the printer that consists of a belt and fastening screws. The figure below illustrates how the belt coupler is attached underneath the printer.

(Fig.A.3)

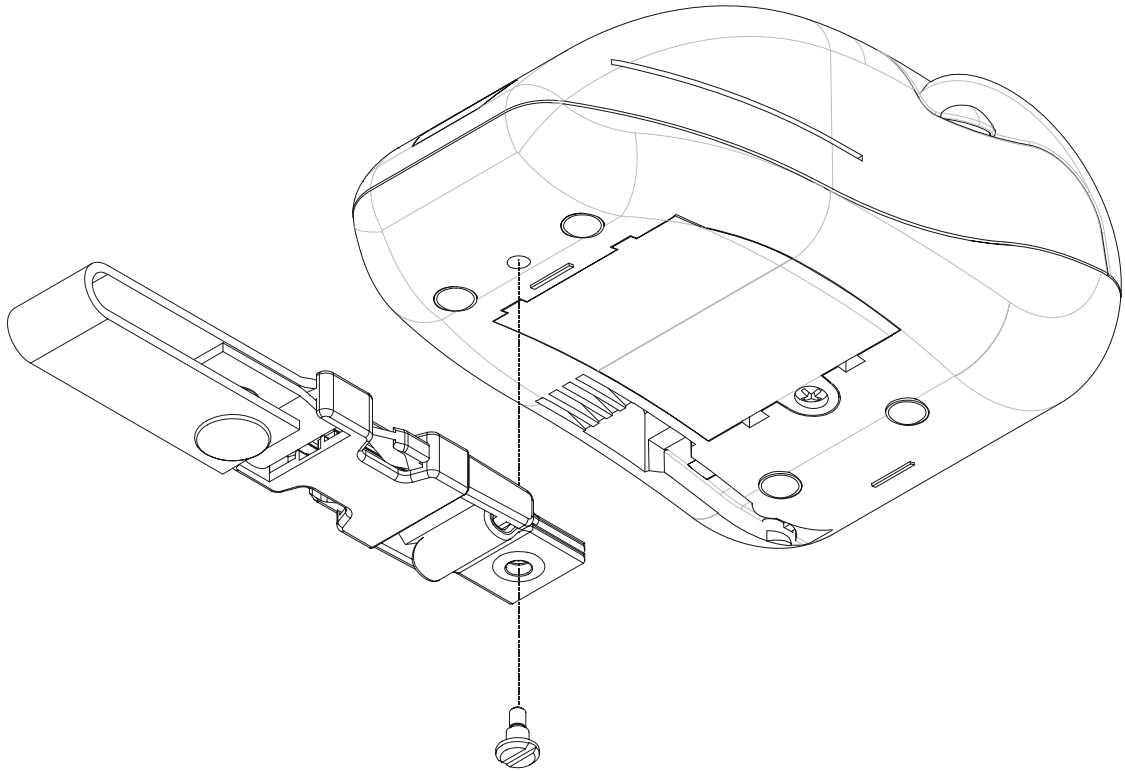

## A.3 SPARE PARTS

(Tab.A.2)

RCT57X50	Roll of thermal paper
BTNIMH-1.2V-1300MAH	NICKEL-CADIUM AA batteries
PCALI-DP-E	Adapter/battery recharger
CB9POLI-PLUG8	Serial cable
VAGANCIO-CINT	Belt loop coupler
VACUSTODIA-CINT	case for belt <i>s'print</i>