

HAS-Interface

Technical Information

Please keep for further use !

Edition date/Rev. date: 26.04.2002
Document no./Rev. no.: TR - E - TI - GB - 0051 - 00
Software version:
File name: TR-E-TI-GB-0051.DOC
Author: MÜJ

**TR - Electronic GmbH
Eglisshalde 6
D-78647 Trossingen**

Germany
Tel. +49 - (0) 7425 / 228-0
Fax +49 - (0) 7425 / 228-33

Imprint

TR-Electronic GmbH
D-78647 Trossingen
Eglishalde 6
Tel.: (0049) 07425/228-0
Fax: (0049) 07425/228-33

© Copyright 2002 TR-Electronic

Right of modification

We reserve the right to modify the technical information contained in this document without prior notice in the interests of ongoing improvements to our products and documentation.

Printing

This manual was produced on a personal computer using MS-Word for Windows. The text was printed in *Arial* type.

Fonts

Italics and **bold** type are used for the title of a document or to emphasize text passages.

Passages written in *Courier* show text which is visible on the display as well as software menu selections.

"< >" refers to keys on your computer keyboard (e.g. <RETURN>).

Note

Text following the "NOTE" symbol describes important features of the respective product.

Copyright Information ©

MS-WORD is a registered trademark of Microsoft Corporation.

Revision History

i

Note:

The cover of this document shows the current revision status and the corresponding date. Since each individual page has its own revision status and date in the footer, there may be different revision statuses within the document.

Document created:

26.04.2002

Revision	Date

Table of contents

1 HAS-Interface (Highspeed-Asynchronous-Serial) 5

- 1.1 Block diagram, standard HAS-encoder 5
- 1.2 Description 5
 - 1.2.1 Telegram structure 5
 - 1.2.2 Interface – hardware without addressing (standard) 6
 - 1.2.3 Interface – hardware with addressing 6
 - 1.2.3.1 Connection example with PK-600 as control-system 7

1 HAS-Interface (Highspeed-Aynchronous-Serial)

1.1 Block diagram, standard HAS-encoder

1.2 Description

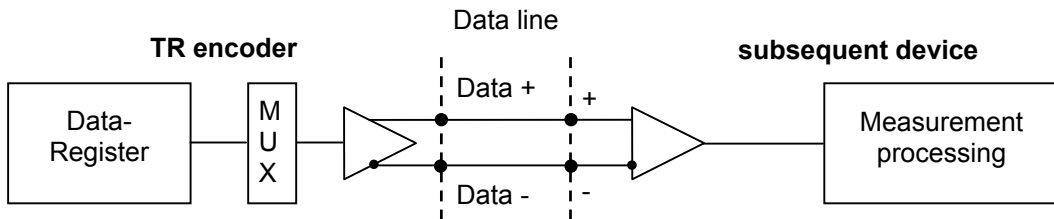

The **HAS** data communication is a **H**ighspeed-**A**ynchronous-**S**erial transmission for binary position data with 24 bits data length. The electric data correspond to the RS422 interface with two lines for the inverted and the not inverted signal.

The baud rate used in the HAS protocol is 125 kBaud. In each case 8 data bit are transferred together with 1 parity, 1 start bit and 1 stop bit. At a position report altogether 4 characters each with 8 bits are transferred. The transmission of a complete position report with pause takes 500µs. Thus, the positions are transferred in 2 kHz rhythm.

To guarantee an error-free data transmission, twisted-pair lines must be used. Under ideal conditions the data transmitting length is max. 1000 m.

1.2.1 Telegram structure

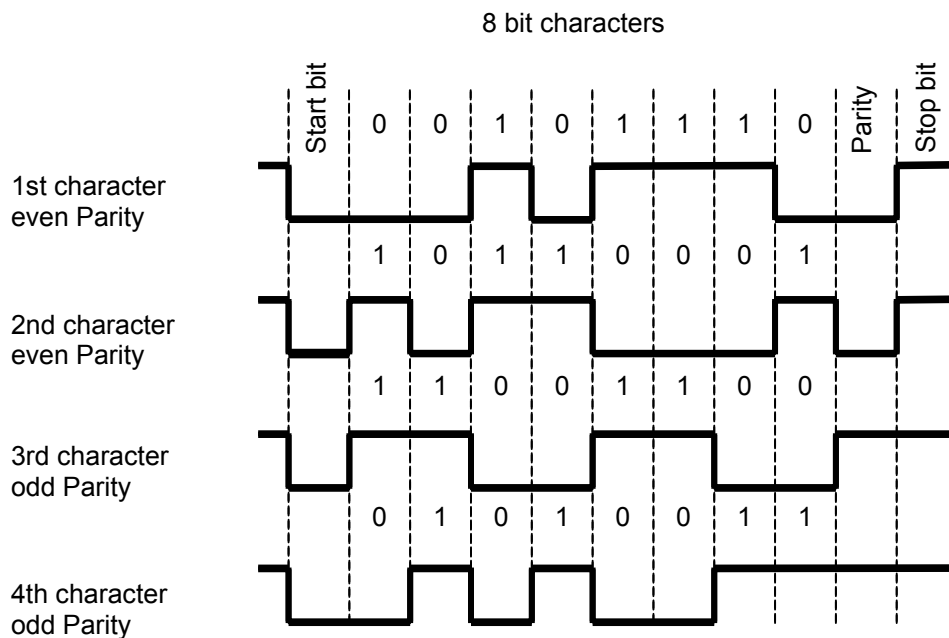

1 st Character	2 ¹⁶	to	2 ²³	Even Parity	
2 nd Character	2 ⁸	to	2 ¹⁵	Even Parity	
3 rd Character	2 ⁰	to	2 ⁷	Odd Parity	
4 th Character	CRC	2 ⁰	to	2 ⁷	Odd Parity

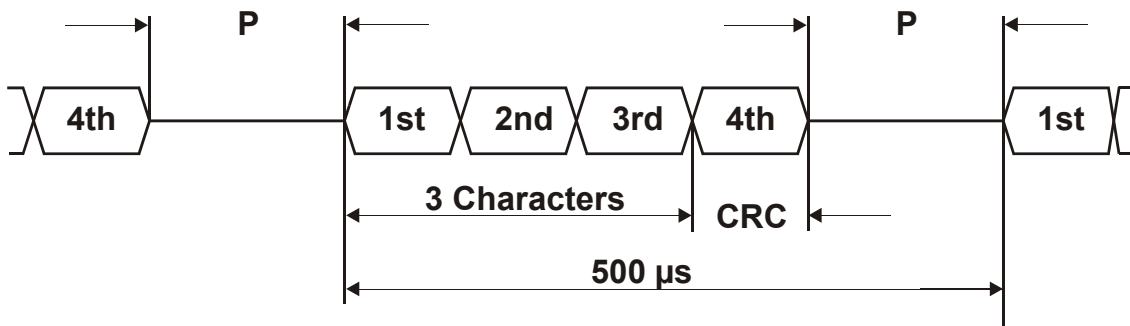

P: pause for synchronization
 Transmission time of one character: 88 µs (theoretical)

1.2.2 Interface – hardware without addressing (standard)

If the encoder is correctly wired and supplied with voltage, the encoder returns permanently and without request its current position data on the data lines.

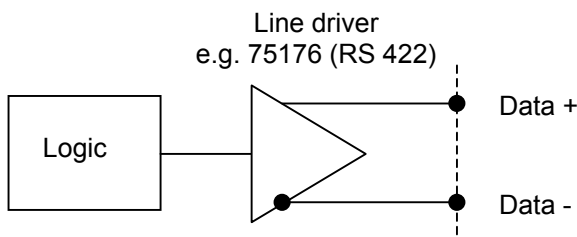

1.2.3 Interface – hardware with addressing

If several axes must be managed, 2 further lines (Adr.+ / Adr. -) are used to switch the desired encoder active (connection example with PK-600 as control-system).

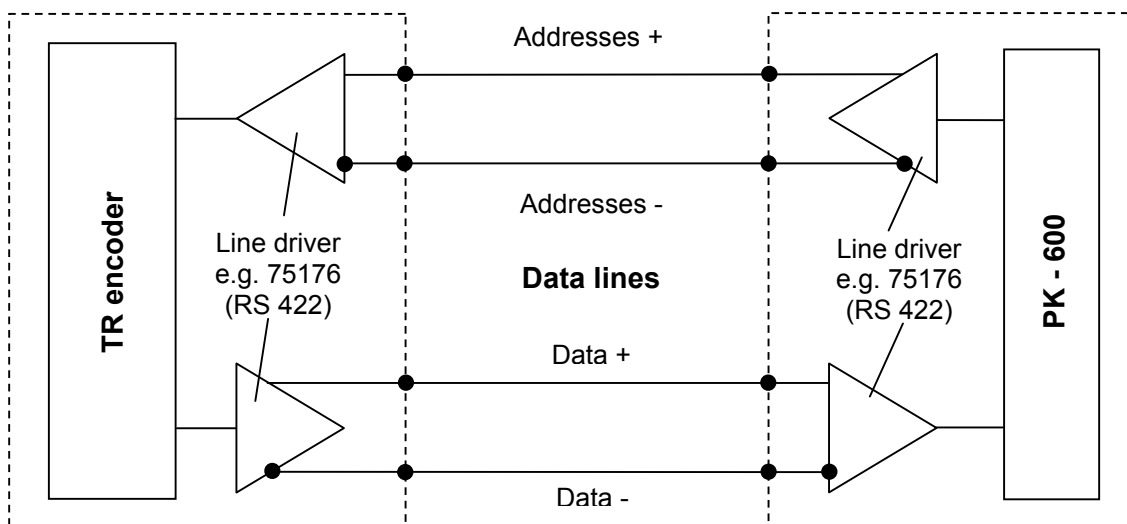

1.2.3.1 Connection example with PK-600 as control-system

