

# epc-W

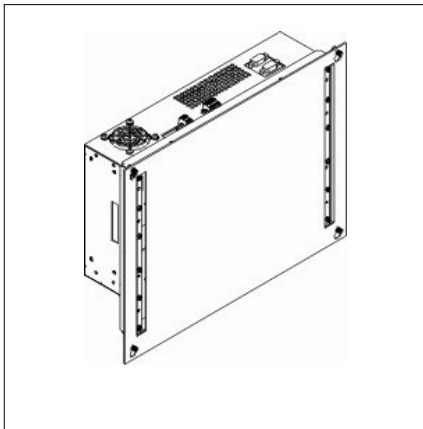

- Industrial approved components
- Scalable ETX CPU Modules
- Compact Design
- Ideal for hard environments / Solid & robust
- Modular System
- Long time availability
- Shock and Vibration approved
- increased security by optional UPS
- 1 field bus interfaces integrated, expandable

### Technical data

#### TFT Module

Display type ..... not integrated / for external use only  
 Resolution ..... up to 2048x1536

#### CPU Board

CPU ..... starting up from Intel® Celeron™ 400MHz to  
 ..... Intel® Pentium® M 1.6GHz Processor  
 Memory ..... up to 1GByte  
 Operating system ..... WIN 2000 / XP, on costumer's request  
 Fieldbus ..... Profibus-DP, other on request  
 Network ..... 10/100 LAN Base-T  
 Interfaces ..... RS232, Printer, PS/2 mouse and keyboard, VGA, USB,  
 ..... optional OnScreen keyboard  
 Drive ..... typical 40GByte hard disk, optional Flash disk  
 ..... Floppy, CD/DVD not available in the box version  
 Monitoring functions ..... temperature, watchdog, fan  
 Free card slot ..... 1x ISA or 1x PCI  
 ..... extended version with 2 PCI + 1x ISA or 3x PCI

#### Electrical data

Power supply ..... +24V DC ± 20%, optional 240V  
 Operating current (Standard configuration) ..... 1A

#### Environmental conditions

EMI ..... EN61000-6-2 according EN61000-4-2, -4-3, -4-4, -4-5, -4-6  
 ..... EN 61000-6-4 according EN55011  
 Protection class ..... IP20  
 Operating temperature [°C] ..... 0...+50  
 Storage temperature [°C] ..... -20...+60  
 Humidity (rel) ..... 90% (non condensing)

#### Dimension

execution 1x ISA or 1x PCI	extended version with 2x PCI + 1x ISA or 3x PCI
External dimension in mm(w/h) ..... 365 x 276	..... 365 x 276
Deepness [mm] ..... 87.5	..... on request
Weight [kg] ..... 7	..... 8

TR Systemtechnik GmbH, Eglisshalde 16, 78647 Trossingen, Tel.: +49 (0) 7425 228-0, Fax: +49 (0) 7425 228-34, www.TRsystems.de, info@trsystems.de